

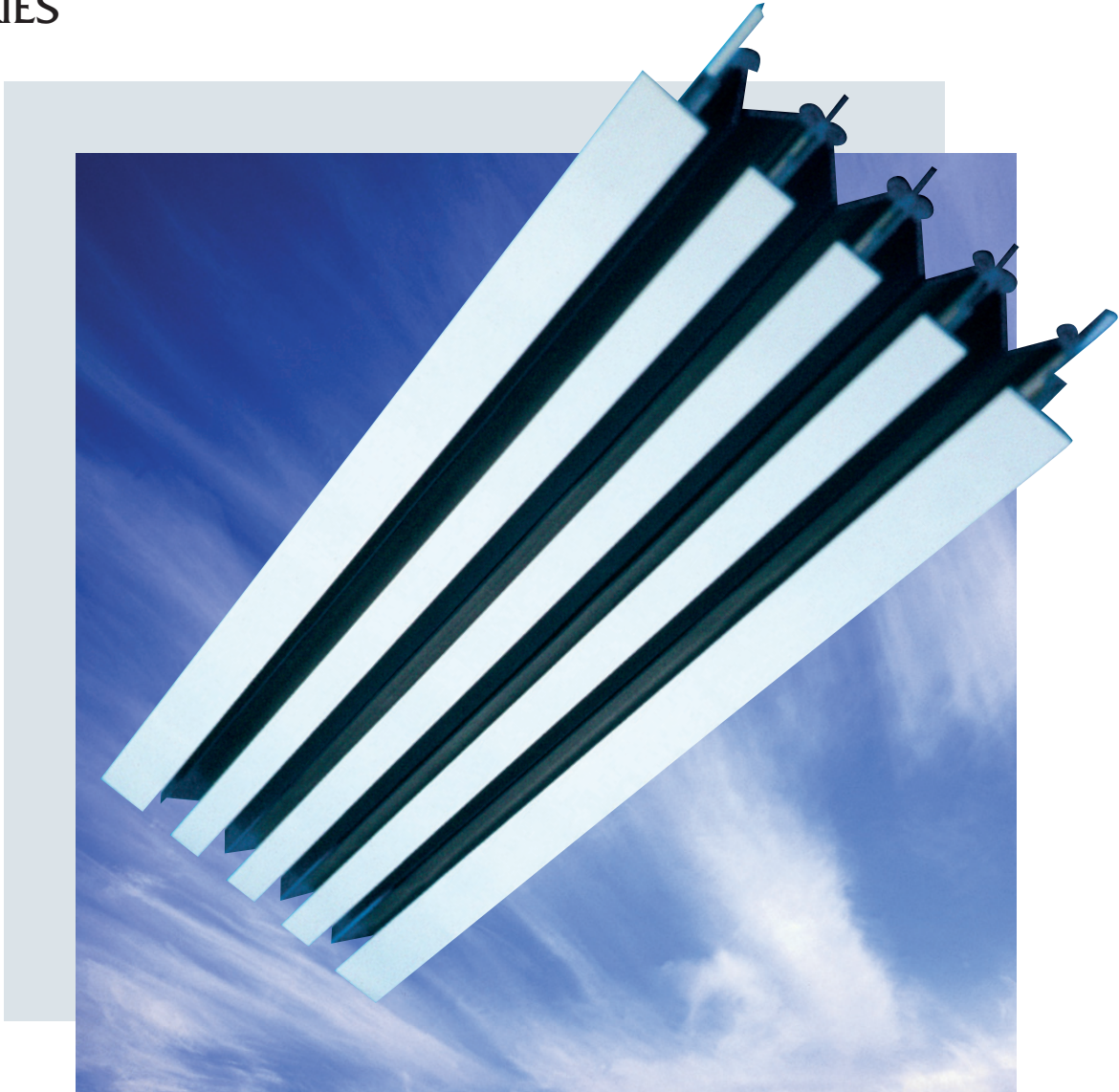

ENGINEERED AIR PRODUCTS

LINEAR SLOT DIFFUSERS
CE SERIES



CE
SERIES

LINEAR SLOT DIFFUSERS

CE SERIES

QUALITY AND EFFICIENCY WITHOUT COMPROMISE

Application

Colman's Model CE is a multi-purpose linear slot diffuser suited to a wide variety of applications. Its simple and cost-effective design, with adjustable blades and optional number of slots, means the diffuser will co-ordinate with most building environments, and ensures it can provide an attractive and economic solution to many air distribution requirements.

Description

The CE linear slot diffuser is designed to give continuous air diffusion with a pleasing aesthetic appearance. Hairline butt joints held by special alignment strips ensure that continuous, unbroken runs of active and dummy sections are readily achieved.

The standard diffuser comprises from one to eight slot sections complete with full length air pattern control blades that allow full adjustment from the face. Constructed from high quality aluminium extrusion in maximum one piece lengths of 3000mm, the design incorporates keyways for alignment and suspension purposes. End caps are supplied as standard for single piece diffusers and for end sections of continuous runs. Special profile and angled end caps can be offered.

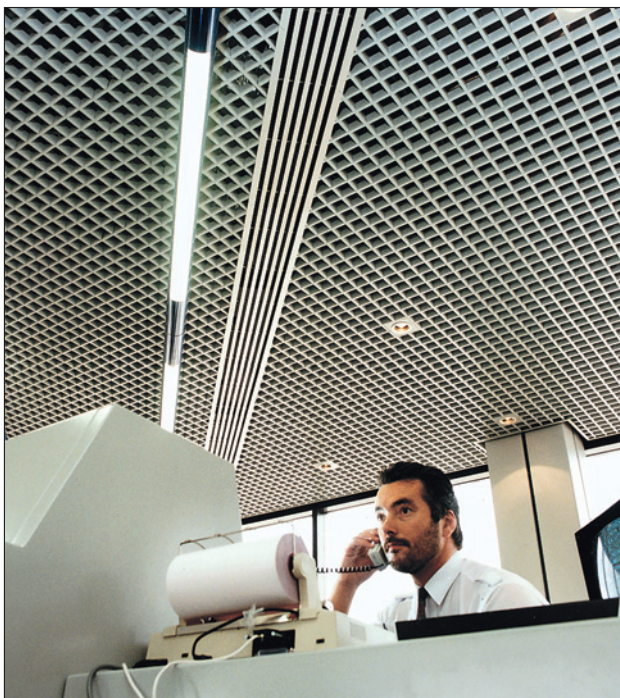

Manchester Airport

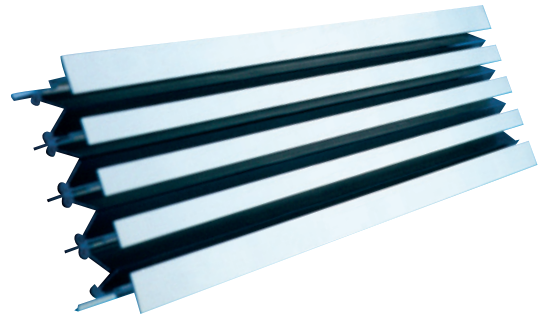

Manchester Airport

Mitred sections are available to most angles and special applications for greater than 8 slots, light fittings and special ceilings.

Fixings

As standard the diffuser is supplied with side suspension brackets for use with drop rods. Colman recommend this technique for continuous line installation. Options include an additional installation frame for use with plaster ceilings and universal brackets for use either with this extra frame or for fixing to a plenum or duct with a prepared opening. The maximum recommended lengths for this method is 3m. Special fixing systems are available on request.

Please note, a separate brochure is available covering installation details of all Colman slot diffusers. Please contact us should you require a copy.

Finish

The slot diffuser is available as standard, powder coated in RAL 9010 Matt White. Please refer to the product coding section within this brochure for a list of other standard finishes. Special finishes are available on request.

Slot Diffuser and CNH Plenum Arrangement Drawing

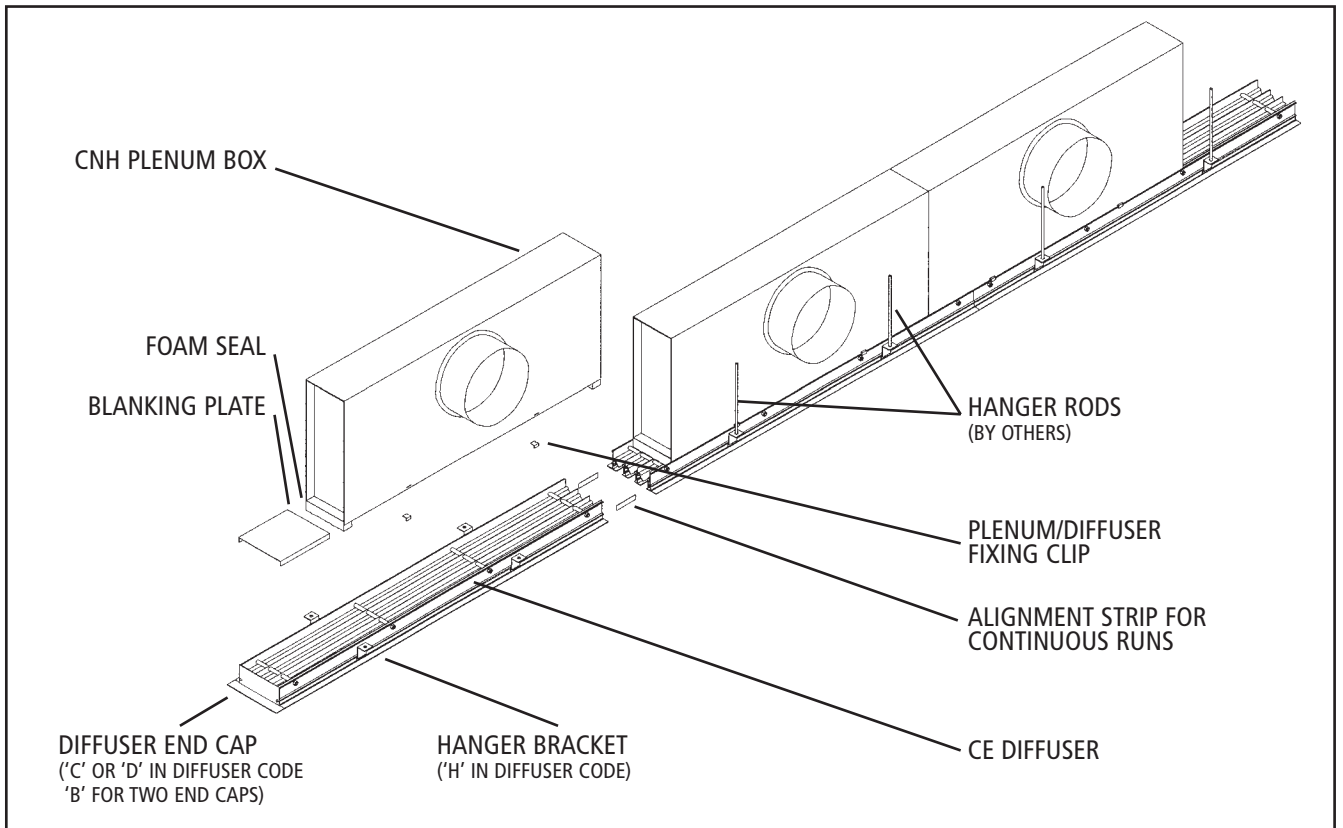

CNH/CNU Plenum Boxes

Colman manufacture a range of high quality, galvanised sheet steel plenum boxes to suit the CE range of slot diffusers. Designed to equalise the air distribution along the diffuser, these plenums are available in standard configurations or purpose made to suit different ceilings, bulkheads or air volumes. For supply air applications they will contain an equalising mesh to equalise the air along the full length of the diffuser. Plenums are normally supplied unlined but can be offered with a variety of acoustic lining materials. Supplied

as standard to a maximum length of 1800mm the units are manufactured to ensure rigidity. Where lengths exceed this maximum, plenums are supplied in even lengths with a single entry spigot per plenum. As standard, plenums are supplied with a central circular spigot but oval or rectangular spigots are also available. Diffuser fixing to the plenum is either via clips (CNH) where the diffuser is fixed first and the plenum is then clipped to the back (as illustrated above) or via universal mounting brackets (CNU) where the plenum is the first fix item.

Blade Setting for Different Air Patterns

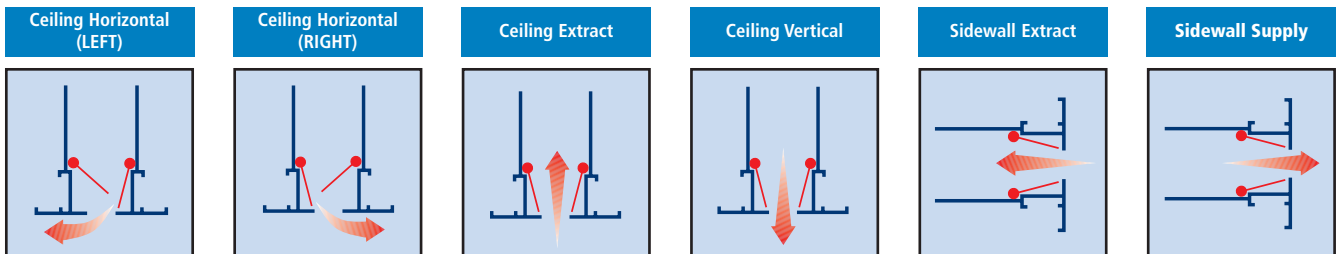

Mitred Corner Options

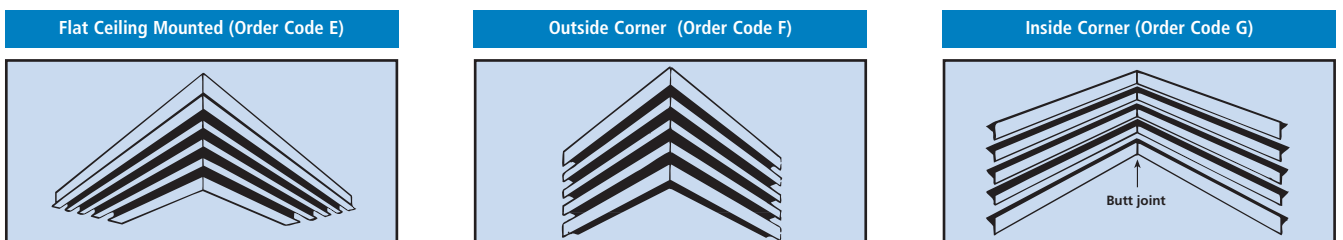

Note: Standard inside leg length is 500mm over flange.

Options and Order Codes

Diffusers

Series	Diffuser	Blade	Accessories	Arrangement	Fixing	Finish
C	E Adjustable Blades Surface Mounted H Standard CE Diffuser with special outer frame Z Blanking Plate only	F Full Blade S Short Blade (300mm) N None 1 Special	A Standard End Caps B Standard End Plates C Non Standard End Caps O None	A Intermediate (No End Caps) B Straight (2 End Caps) C Straight (RH End Caps) D Straight (LH End Caps) E Standard Mitre (Flat Ceiling Mounted) F Standard Mitre (Sidewall Outside Corner) G Standard Mitre (Sidewall Inside Corner) H Non Standard Mitre (Flat Ceiling Mounted) J Non Standard Mitre (Sidewall Outside Corner) K Non Standard Mitre (Sidewall Inside Corner) 1 Special	O None H Hanger Brackets P Plaster Mounting Frame X Extended Hanger Brackets U Standard Universal Brackets 1 Special	A Anodised 9 Satin Anodised F RAL 9010 Matt White O Mill Finish C BS00E55 Gloss White H BS00E55 Satin White D BS00E55 Matt White E RAL 9010 Gloss White G RAL 9010 Satin White 3 Aluminium 1 Special

Note: Standard Mitre - 90 degrees 500mm inside legs. Non Standard Mitres - angles TBA - inside legs 500mm. (Templates may be required.)

Note: The items shown in red print above and below and in the order code example are the standard options for this product. Unless shown otherwise on any quotation or order the units will be supplied in this configuration.

Example of Order Codes

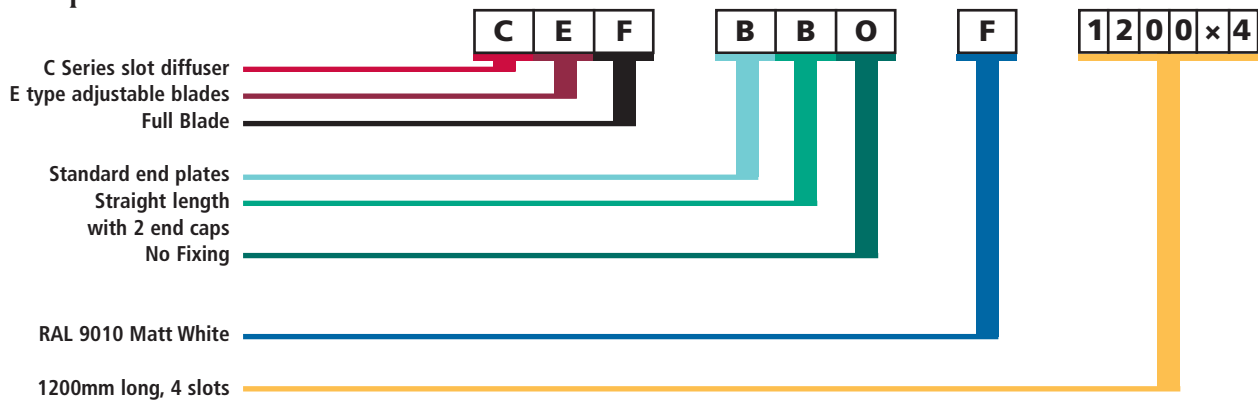

CE Plenum Boxes

Series	Lining	Installation Method	Accessories	Arrangement	Spigot Type	Spigot Size Round or Square
C	L Lined (6mm Bestobell) N Unlined 1 Special	H Clip on Plenum with Hanger brackets P Plaster Mounting Frame U Universal Brackets 1 Special	O None C Cord Operated Opposed Blade Damper D Cord Operated Opposed Blade Dampers (Matt Black) M Cord Operated Monoblade Damper N Cord Operated Monoblade Damper (Painted Matt Black internally) P Internally Painted Matt Black 1 Special	S Supply E Extract 1 Special	R Round - Side Entry S Square - Side Entry T Round - Top Entry W Round - Side Entry Flush with Top X Square - Side Entry Flush with Top Y Square - Top Entry 1 Special	A 100 B 125 C 150 D 200 E 250 F 300 G 350 H 400 J 450 K 500 L 160 M 180 N 315 P 280 R 225 S 355 T 175 1 Special

Note:
Maximum size monoblade –
400 diameter or 350 square

Specification

The CE slot diffuser is manufactured from 1.5mm extruded aluminium to BS 1474/6063T6. Outer frames are formed from extruded aluminium and contain key ways to facilitate independent suspension of the unit from all surfaces. This shall be achieved by use of suspension brackets or universal fixing brackets. The slots shall be 19mm wide and contain adjustable pattern blades, to provide control of the air pattern in either direction along the length of the diffuser or to provide positive blanking of a section or slot. The blades to be anodised black aluminium with two blades per slot.

Selection Information

The following pages give details on how to correctly select the CE Slot Diffusers, together with a worked example. Please read the notes carefully and contact us should you have any queries.

Table 1: Diffuser length correction figures

Active Diffuser Length (m)	Factor	NC Correction
0.3	0.52	-5
0.6	0.88	-2
0.9	0.98	0
1	1	0
1.2	1.04	1
1.5	1.09	2
1.8	1.14	3
2.1	1.17	3
2.4	1.19	4
2.7	1.2	4
3.0+	1.21	5

Table 2: Spigot velocity against NC rating

Sound Rating NC	Spigot Velocity m/s
25	2.5
30	3
35	3.5
40	4.5

Table 3: Minimum cross section areas

Slots	m ² /m
1	0.008
2	0.015
3	0.022
4	0.03
5	0.038
6	0.046
7	0.055
8	0.06

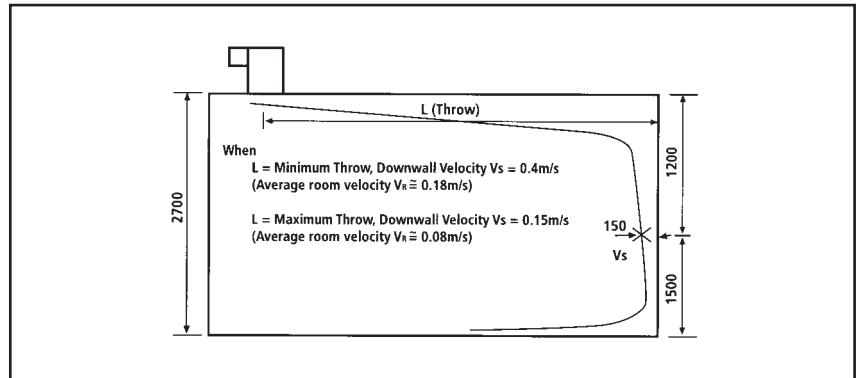

Throw

Throw and NC data is given for 1m active lengths, for other lengths use the correction figures given in Table 1. If two diffusers are to throw towards each other, select an air volume that gives a maximum throw equal to half the distance between the two.

Plenums

Select the appropriate spigot velocity to match the NC rating required, as per Table 2.

The plenum sizes shown in the brochure have been selected for the minimum recommended size for even distribution along the diffuser for a centre fed, constant cross-section box. The minimum cross-sectional areas are shown in Table 3 and these can be increased when the dimensions of the plenum are changed. For lengths other than 1m, multiply these figures by the plenum length.

To obtain the minimum height, divide the cross-sectional area by the width (see back page) and add 100mm to allow for the equalising mesh and the diffuser.

Pressure Drop

The pressure drop is given for the diffuser only.

Typical Selection

Given: Room Size of 5m x 5m x 2.7m high
 Required NC level of 30
 10 Air changes per Hour

1) Calculate Air Volume required:

Room Volume = Length - 5m x Width - 5m x Height - 2.7m = 67.5m³
 Multiplied by the required number of air changes 10 = 675m³/hr
 Divided by the number of seconds per hour 3600 = 0.188m³/s

2) Decide Position of Diffuser:

Assuming the diffuser is positioned 500mm from one wall, a throw of 4.5m would be required to fully distribute the air in the room.

3) Select Number of Slots:

From the performance data given on page 6, a 4 slot diffuser with a volume of 0.08m³/s/m would give a throw of between 3.7m and 5.0m, at < NC 20, as selections should be based on mid range, a 4 slot diffuser would be suitable in this instance.

4) Calculate Active Length:

$$\frac{\text{Total volume}}{0.188} \div \frac{\text{selected volume}}{0.080} = 2.35\text{m}$$

As this length exceeds the maximum recommended plenum length of 1800mm, 2 plenums would be required, with their length given by:

$$\frac{\text{Total active length}}{2.35} \div \frac{\text{number of plenums}}{2} = 1.175\text{m}$$

So the selection in this case, is for: 1 No. 4 slot diffuser @ 2.35m
 2 No. plenums @ 1.175m

5) Select Spigot Size:

Spigot Area =
 Total volume ÷ number of plenums ÷ maximum allowed velocity
 $\frac{0.188}{2} \div 3\text{m/s} = 0.0313 \text{ m}^2$
 Area of 200mm Dia spigot = $\pi r^2 = 3.142 \times 0.1^2 = 0.0314 \text{ m}^2$
 Therefore each plenum would be fitted with 1, centrally positioned 200mm Dia spigot.

Note: Although the basic selection is now made the points shown on the right should be checked.

Check No. 1 – Ceiling Height

For ceiling heights greater than 2.7m, the throw is reduced by 5% for each additional 0.3m up to a maximum ceiling height of 4.3m.

Check No. 2 – Active Length

As the active length in the performance tables is per metre, and the total plenum length is above this the correction factor given in Table 1 must be applied.

Minimum Throw 3.70m x 1.19 = 4.4m
 Maximum Throw 5.00m x 1.19 = 5.95m

This confirms that the selected diffuser and plenums will achieve the required throw of 4.5m.

Note: If the plenums have an inactive gap of more than 1m use the individual plenum length in the above check.

Check No. 3 – NC Level

To ensure that the air velocity in the spigot does not cause excessive noise the figures given in Table 2 should be noted.

$$\text{i.e. Total volume} \div \text{number of plenums} \div \text{area of each spigot} = \text{Velocity}$$

$$\text{So - } \frac{0.188}{2} \div 0.0314 = 2.994\text{m/s}$$

From Table 2 this gives NC 30, which is within the specified limit.

Check No. 4 – Plenum Height

If site conditions dictate a height limitation, the following formula can be used to check the minimum recommended height for the plenums. If these are found to be too high please contact the sales office for advice on alternative plenum arrangements.

Take the minimum cross sectional area per metre from Table 3 and multiply by the plenum length

$$0.03 \times 1.175 = 0.035\text{m}^2$$

Height = cross sectional area ÷ diffuser width (see back page)

$$\frac{0.035}{0.156} = 0.224\text{m}$$

Plus clearance for spigot and equalising mesh = 0.100m
 Gives an overall minimum height = 0.324m

CE Ceiling Supply

Air Volume m³/s/m	Number of Slots	Pressure Drop N/m²	Throw m		Sound Rating NC
			Min.	Max.	
.015	1	2	1.5	2.1	20
.020	1	4	2.0	2.8	21
.030	1	8	3.1	4.2	24
	2	2	2.7	3.7	-
.040	1	15	4.1	5.6	28
	2	4	3.3	4.6	-
.050	1	23	5.7	7.0	31
	2	6	4.1	5.5	21
	3	2	2.9	3.7	-
.060	1	33	6.2	8.4	34
	2	8	4.8	6.5	23
	3	4	3.4	4.6	-
	4	2	2.8	3.9	-
.070	1	45	7.2	9.8	37
	2	11	5.5	7.4	25
	3	5	4.0	5.4	-
	4	3	3.2	4.4	-
.080	1	58	8.3	11.2	41
	2	15	6.2	8.3	27
	3	6	4.6	6.2	-
	4	4	3.7	5.0	-
.090	1	74	9.3	11.6	46
	2	19	6.8	9.2	29
	3	8	5.1	6.9	-
	4	5	4.1	5.6	-
.100	2	21	7.5	10.2	32
	3	10	5.7	7.7	20
	4	6	4.5	6.2	-
	5	4	3.8	5.2	-
.120	2	31	8.9	12.1	36
	3	14	6.9	9.3	25
	4	8	5.4	7.4	-
	5	5	4.6	6.2	-
	6	4	4.0	5.4	-
.140	2	42	10.3	13.9	38
	3	19	8.0	10.8	28
	4	11	6.3	8.5	22
	5	7	5.3	7.2	-
	6	5	4.6	6.2	-
	7	4	4.1	5.7	-
.160	3	25	9.1	12.4	31
	4	15	7.2	9.7	25
	5	9	6.1	8.2	20
	6	6	5.2	7.1	-
	7	5	4.7	6.4	-
	8	3	4.0	5.5	-
.180	3	32	10.3	13.9	36
	4	19	8.0	10.8	30
	5	12	6.8	9.2	24
	6	8	5.9	8.0	20
	7	6	5.3	7.2	-
	8	4	4.6	6.2	-

CE Extract

Air Volume m³/s/m	Number of Slots	Pressure Drop N/m²	Throw m		Sound Rating NC
			Min.	Max.	
.200	3	39	11.4	15.4	41
	4	23	8.9	12.0	35
	5	15	7.5	10.2	28
	6	10	6.5	8.9	25
	7	7	5.9	8.0	22
	8	5	5.1	6.9	20
.220	3	47	12.5	17.0	46
	4	28	9.7	13.2	37
	5	18	8.3	11.2	30
	6	12	7.2	9.7	26
	7	9	6.5	8.8	23
	8	7	5.6	7.6	21
.240	4	33	10.6	14.4	39
	5	21	9.0	12.2	32
	6	14	7.8	10.6	27
	7	10	7.0	9.6	24
	8	8	6.1	8.3	22
.260	4	39	11.5	15.5	42
	5	25	9.8	13.2	36
	6	17	8.5	11.5	31
	7	12	7.6	10.4	27
	8	9	6.7	9.1	25
.280	4	45	12.4	16.7	45
	5	28	10.5	14.2	39
	6	19	9.1	12.4	32
	7	14	8.2	11.1	30
	8	11	7.2	9.8	27
.300	4	52	13.2	17.8	48
	5	33	11.3	15.7	41
	6	22	9.8	13.3	34
	7	16	8.8	11.9	32
	8	12	7.7	10.5	29
.320	5	37	12.0	16.2	43
	6	25	10.4	14.1	36
	7	18	9.4	12.7	34
	8	14	8.3	11.2	32
.360	5	47	13.5	18.2	45
	6	32	11.7	15.9	39
	7	23	10.6	14.2	36
	8	18	9.3	12.6	34
.400	6	40	13.0	17.6	42
	7	29	11.7	15.8	38
	8	22	10.4	14.0	36
.440	6	48	14.3	19.4	45
	7	35	12.8	17.4	40
	8	26	11.4	15.4	38
.480	7	41	14.0	18.0	42
	8	31	12.5	16.9	40
.520	7	48	15.2	20.5	44
	8	37	13.6	18.4	42
.560	7	56	16.3	22.0	47
	8	42	14.6	19.7	45
.600	8	49	15.6	21.1	48

Air Volume m³/s/m	Number of Slots	Pressure Drop N/m²	Sound Rating NC	
			Min.	Max.
.040	1	7	-	-
.060	1	17	19	-
.080	1	30	26	-
	2	8	-	-
.100	1	46	32	-
	2	13	20	-
	3	5	-	-
.120	1	67	39	-
	2	19	22	-
	3	7	-	-
.140	2	26	25	-
	3	10	-	-
.160	2	34	29	-
	3	13	21	-
	4	8	-	-
.180	2	42	34	-
	3	16	24	-
	4	10	-	-
.200	2	52	36	-
	3	20	26	-
	4	12	-	-
.220	2	63	38	-
	3	24	28	-
	4	15	24	-
.240	3	29	33	-
	4	18	26	-
	5	11	20	-
.260	3	34	34	-
	4	21	28	-
	5	13	23	-
	6	9	-	-
.280	3	39	36	-
	4	24	30	-
	5	15	24	-
	6	10	18	-
.300	3	45	39	-
	4	28	32	-
	5	17	26	-
	6	12	22	-
.320	4	32	33	-
	5	19	27	-
	6	13	23	-
	7	10	-	-
.360	4	40	35	-
	5	24	29	-
	6	17	25	-
	7	13	20	-
	8	10	-	-
.400	4	49	38	-
	5	30	32	-
	6	21	28	-
	7	16	22	-
	8	12	22	-
.440	5	36	36	-
	6	25	31	-
	7	19	25	-
	8	15	24	-
.520	6	35	34	-
	7	27	30	-
	8	21	28	-
.600	7	34	35	-
	8	32	33	-

CE Sidewall Supply

Air Volume m³/s/m	Number of Slots	Pressure Drop N/m²	Throw m		Sound Rating NC
			Min.	Max.	
.030	1	6	2.3	3.1	-
.040	1	10	3.1	4.1	-
	2	3	1.5	2.1	-
.050	1	16	3.8	5.2	-
	2	4	1.9	2.6	-
.060	1	23	4.6	6.2	21
	2	6	2.3	3.2	-
.070	1	31	5.4	7.2	28
	2	8	2.7	3.7	-
.080	1	40	6.1	8.3	31
	2	11	3.1	4.2	-
.090	1	51	6.9	9.3	35
	2	14	3.5	4.7	-
	3	6	2.6	3.6	-
.100	1	63	7.6	10.2	39
	2	18	3.9	5.3	22
	3	8	2.9	4.0	-
	4	4	2.4	3.5	-
.120	2	24	4.6	6.4	26
	3	11	3.5	4.8	-
	4	6	2.9	4.2	-
	5	4	2.3	3.4	-
.140	2	33	5.4	7.4	30
	3	15	4.0	5.5	24
	4	8	3.4	4.9	-
	5	5	2.7	3.9	-
	6	4	2.2	3.2	-
.160	2	43	6.2	8.4	32
	3	19	4.6	6.3	26
	4	11	3.9	5.6	-
	5	7	3.1	4.5	-
	6	5	2.5	3.7	-
	7	3	2.2	3.3	-
.180	2	54	7.0	9.5	37
	3	24	5.2	7.1	30
	4	14	4.4	6.4	21
	5	8	3.5	5.1	-
	6	6	2.8	4.1	-
	7	4	2.4	3.7	-
	8	3	2.0	3.5	-
.200	2	67	7.7	10.6	39
	3	30	5.8	7.9	33
	4	17	4.8	7.1	25
	5	10	3.9	5.6	-
	6	7	3.1	4.6	-
	7	5	2.7	4.0	-
	8	4	2.2	3.8	-
.220	2	81	8.5	11.6	41
	3	36	6.4	8.6	36
	4	20	5.3	7.7	29
	5	13	4.2	6.2	21
	6	9	3.4	5.0	-
	7	6	2.9	4.4	-
	8	3	2.5	4.2	-

Air Volume m³/s/m	Number of Slots	Pressure Drop N/m²	Throw m		Sound Rating NC
			Min.	Max.	
.240	3	43	7.0	9.4	38
	4	24	5.8	8.5	30
	5	15	4.6	6.7	24
	6	11	3.8	5.5	-
	7	8	3.2	4.8	-
	8	6	2.7	4.6	-
.260	3	51	7.6	10.2	41
	4	28	6.3	9.2	32
	5	17	5.0	7.3	27
	6	12	4.1	6.0	20
	7	9	3.4	5.2	-
	8	7	2.9	4.9	-
.280	3	59	8.1	10.9	44
	4	33	6.8	9.9	33
	5	20	5.4	7.8	29
	6	14	4.4	6.4	21
	7	11	3.7	5.6	20
	8	8	3.1	5.3	19
.300	3	68	8.7	11.7	48
	4	38	7.3	10.6	34
	5	23	5.8	8.4	31
	6	16	4.7	6.9	23
	7	12	3.9	6.0	21
	8	9	3.4	5.6	-
.320	3	77	9.3	12.5	50
	4	43	7.8	11.3	37
	5	26	6.1	8.9	33
	6	19	5.0	7.3	26
	7	14	4.2	6.4	23
	8	11	3.6	6.0	20
.360	4	54	8.7	12.7	41
	5	33	6.9	10.0	36
	6	24	5.7	8.2	30
	7	17	4.7	7.1	25
	8	13	4.0	6.7	22
.400	4	67	9.7	14.1	45
	5	41	7.6	11.1	38
	6	29	6.3	9.2	33
	7	21	5.2	7.9	28
	8	16	4.5	7.4	25
.440	5	50	8.4	12.2	40
	6	35	6.9	10.1	37
	7	26	5.6	8.7	32
	8	20	5.0	8.1	29
.480	6	42	7.5	11.0	41
	7	31	6.2	9.4	32
	8	24			

Model CEO Diffuser with CNU Plenum

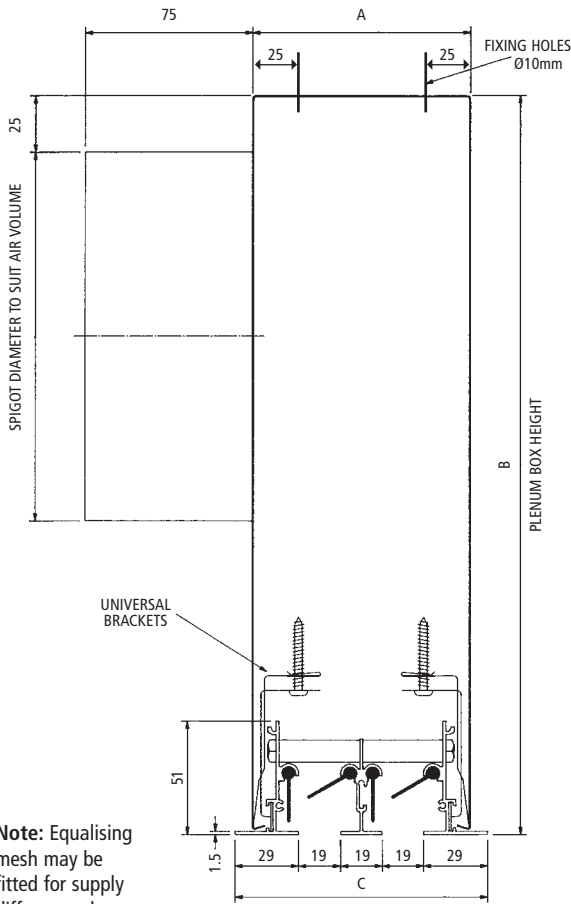

Note: Equalising mesh may be fitted for supply diffusers only

No of slots	A	B	C
1	62	305	77
2	100	305	115
3	138	381	153
4	176	381	191
5	214	444	229
6	252	444	267
7	290	508	305
8	328	508	343

Model CEO Diffuser with CNH Plenum

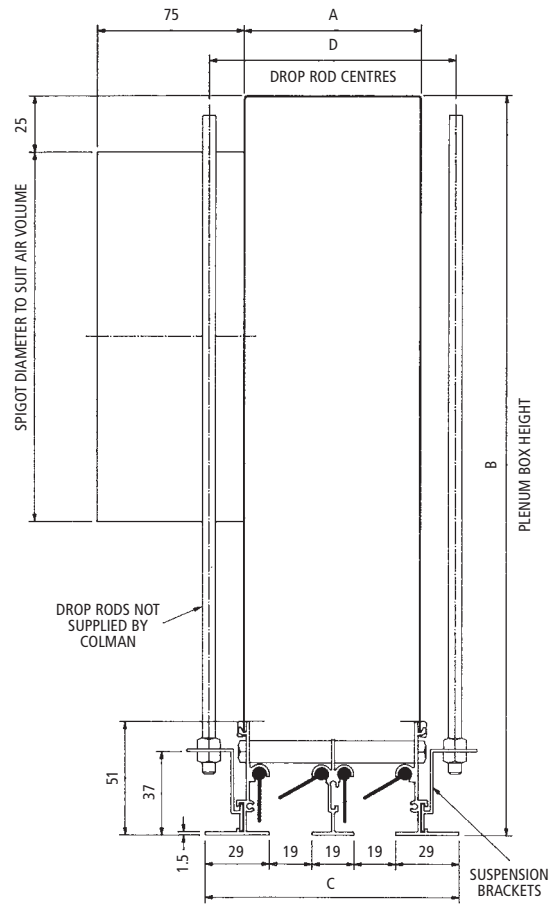

(Recommended for continuous runs)

No of slots	A	B	C	D
1	42	305	77	70
2	80	305	115	108
3	118	381	153	146
4	156	381	191	184
5	194	444	229	222
6	232	444	267	260
7	270	508	305	298
8	308	508	343	336

Model CEO Diffuser with CNP Plenum and plaster mounting frame

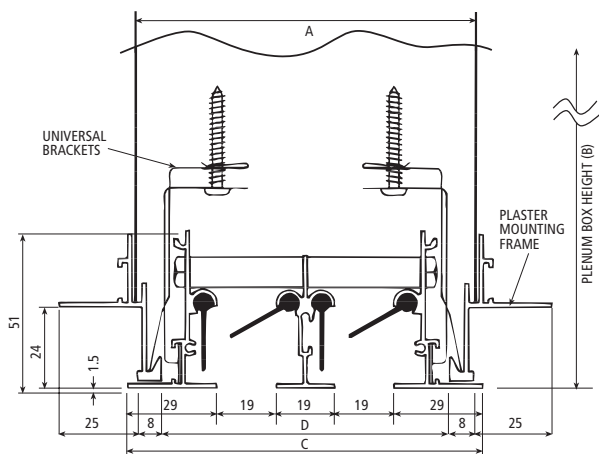

No of slots	A	B	C	D
1	73	305	77	55
2	111	305	115	93
3	149	381	153	131
4	187	381	191	169
5	225	444	229	207
6	263	444	267	245
7	301	508	305	283
8	339	508	343	321

Longitudinal Section of Diffuser

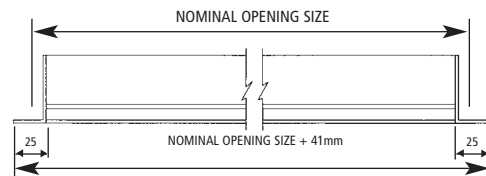

Weight Kg/m

No. Slots	1	2	3	4	5	6	7	8
Diffuser	1.2	1.9	2.6	3.3	4.0	4.7	5.4	6.1
Plenum	4.7	5.1	6.5	6.9	8.1	8.5	9.7	10.2

For Plaster Mounting frame add 1 Kg/m

Also available: CD High Capacity Slot Diffuser. CB Slot Diffuser.

PRODUCT RANGES

GRILLES	DIFFUSERS	LOUVRES
Linear Bar	Linear Slot	External
Ceiling	Louvre Face	Circular
Sidewall	Sidewall	Door
Floor	Perforated Face	Screens
Computer Floor	Circular	Penthouse
Cill	Swirl	Sand Louvres
Single & Double Deflection	Ceiling	Roof Louvres
Egg Crate	Sidewall Fixed & Adjustable	
Hinged Core	Jet Flow / Nozzle	
Door Transfer	Repus Displacement Ventilation	
Security and Prison		
Supply and Extract Valves		

BESPOKE SERVICE

We offer a bespoke design service where standard products do not fit the requirements of the build, we also supply products in special colours and finishes including bronze, brass, gold and chrome to meet Architectural design specifications.



ENGINEERED AIR
PRODUCTS

Colman Air Distribution Limited

Unit 7, High Carr Business Park
Decade Close, Newcastle-Under-Lyme
Stoke-on-Trent, Staffordshire ST5 7UH

Telephone: +44 (0)1782 564383
www.colmanad.com

We reserve the right to alter specifications without notice and products will sometimes be supplied with modifications which do not strictly comply with the descriptions and illustrations in this publication.