

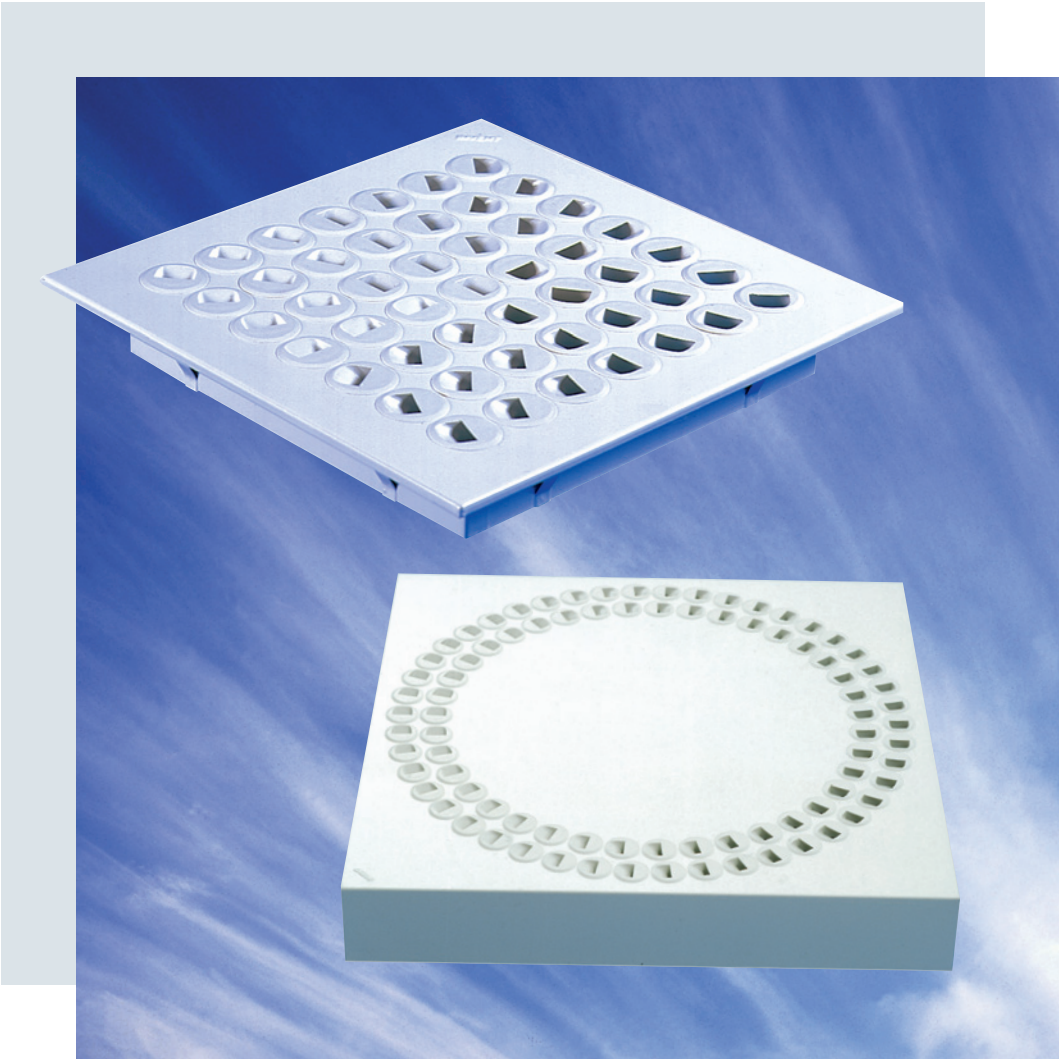

ENGINEERED AIR PRODUCTS

# NOZZLE DIFFUSERS

## N SERIES



N

SERIES

# N SERIES

## NOZZLE DIFFUSER

### CONTENTS

	Page
Introduction	3
Principles of Operation	4
Ceiling Application (Square Neck)	8
Ceiling Application (Round Neck)	14
Sidewall Application	16
Duct Mounted Application	19
Linear Application	21
Projects	23

# Introduction

## Application

'N' Series range of nozzle diffusers are based on a patented nozzle design that allows architects and consultants to have total flexibility when considering their air distribution requirements. The nozzles rotate so that any air pattern can be accommodated and they are available in a wide range of colours to match their surroundings. This brochure provides many examples of the tremendous possibilities this revolutionary product provides. The diffusers have been developed to attain maximum induction and coanda-effect. Thus air from the room is drawn into the diffuser's air streams and cooling is achieved outside of the occupied zone creating comfortable air movement and temperature conditions.

Where a VAV system is being designed this requires diffusers that maintain a high induction effect even at reduced air displacement levels. 'N' Series diffusers provide this flexibility and may be incorporated directly into the standard design.

## Description

N Series diffusers comprise a number of circular nozzles that each emit an air stream at approx. 30° to the surface they are mounted in. The nozzles can be individually swivelled through 360° allowing many different distribution patterns to be generated.

The patented design of the nozzles prevents the distribution pattern from affecting the pressure drop ( $\Delta P$ ), or noise level. Readjustment of the pattern can therefore be made whenever necessary without affecting any of these parameters.

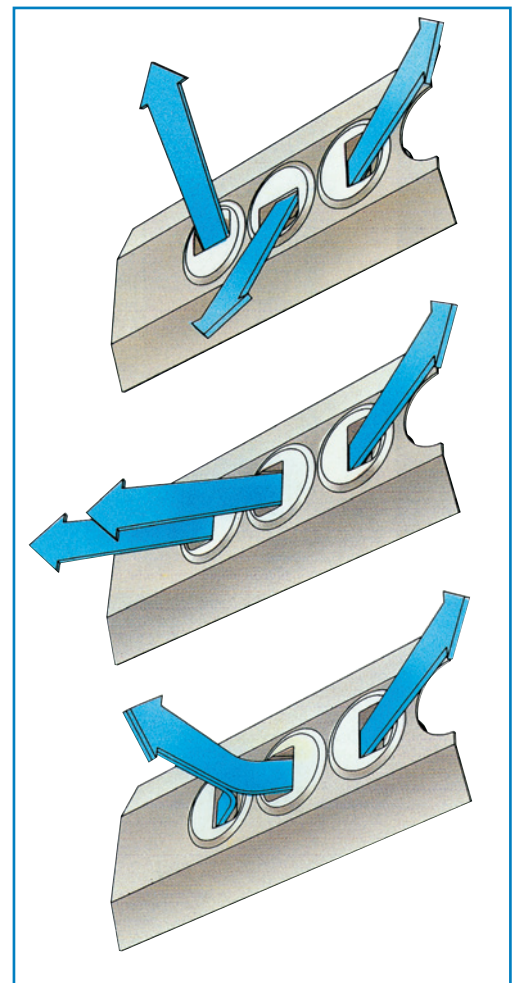

Typical installation

# PRINCIPLES OF OPERATION

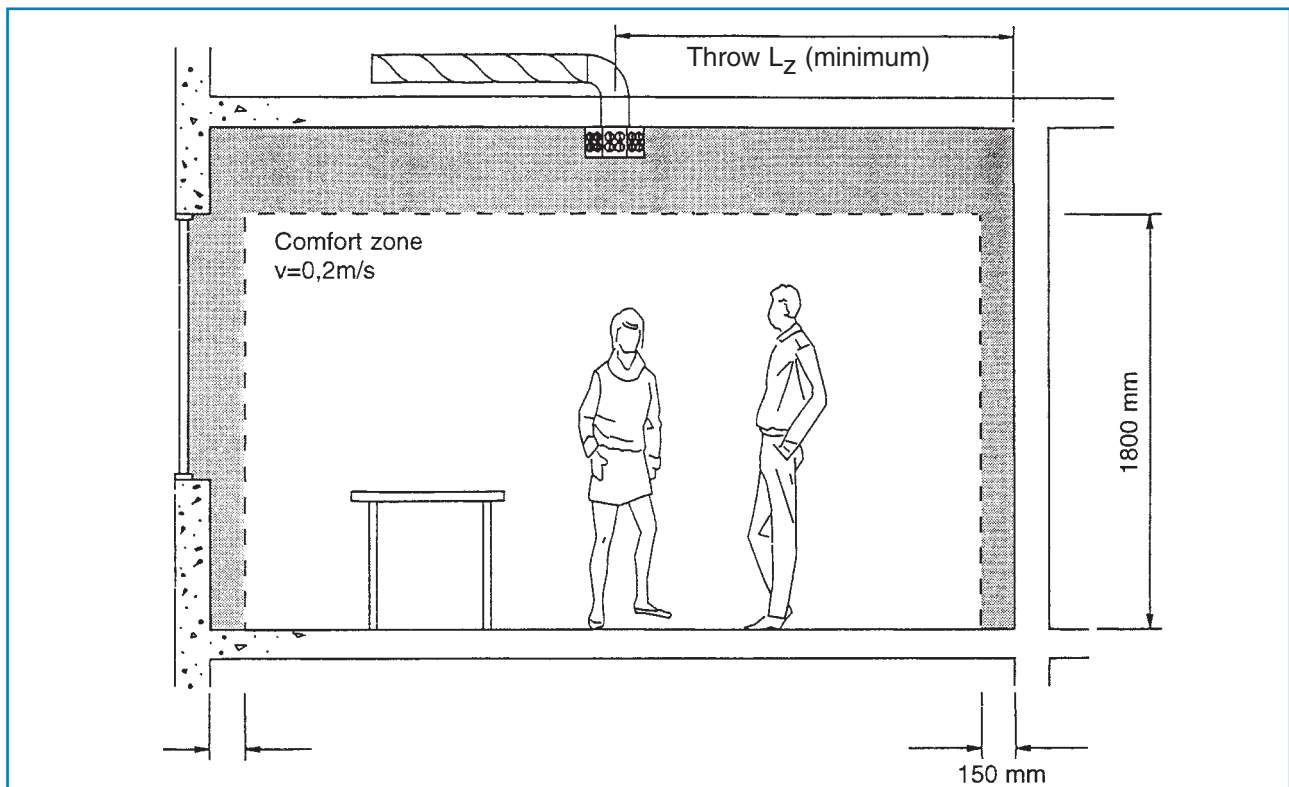

## Throw

Throw  $L_Z$  is defined as the minimum distance from diffuser to wall without exceeding an air velocity of 0.2 m/s in the occupied zone.

Select the smallest diffuser which will give an adequate throw, and an air displacement greater than the required minimum air displacement.

The minimum distance to the nearest diffuser is  $L_Z \times 2 = 2L_Z$ .

$L_Z$  in the charts is given for a ceiling height of 2.45m, and isothermal conditions. At greater ceiling heights  $L_Z$  is reduced, and with greater temperature difference ( $^{\circ}\text{t}$ ),  $L_Z$  is increased.

## Nozzle Settings

The standard nozzle setting is given for each diffuser model. Other nozzle settings may be made on site, or the diffusers may be supplied with the desired settings, after consultation.

## Colours

The standard colour is RAL 9010. Other colours can be supplied on demand, but will incur an additional charge.

## Supplied Cool Air

The suitability of a diffuser for delivering temperate air depends on the air stream's ability to propel the surrounding air mass. This is known as the induction effect. The greater the induction effect of a given diffuser, the more suitable it is for air supply.

The effect of the airstream adhering to the ceiling surface (coanda-effect) diminishes with reduced air velocity.

At a velocity of 0.35 m/s the coanda-effect ceases entirely. If the air stream at this point is cooled, a cold down-draught will be created. It is therefore important that the air stream has a large induction effect so that equalization of temperature takes place before the air velocity reaches 0.35 m/s.

Air supply diffusers with a short 'throw', are more suitable for distribution than those with a long 'throw'.

N-Series diffuser, with their unique nozzle construction, are especially well suited for delivering cooled air.

The construction of the nozzles, together with the possibility of individual adjustment, eliminates the risk of cold down-draughts. In addition the nozzles attain an extremely high induction effect firstly because each nozzle induces individually, and secondly because the shape of the air stream gives a large surface area in comparison to its cross section.

The air stream's flat cross-section gives a large surface area creating a high induction effect.

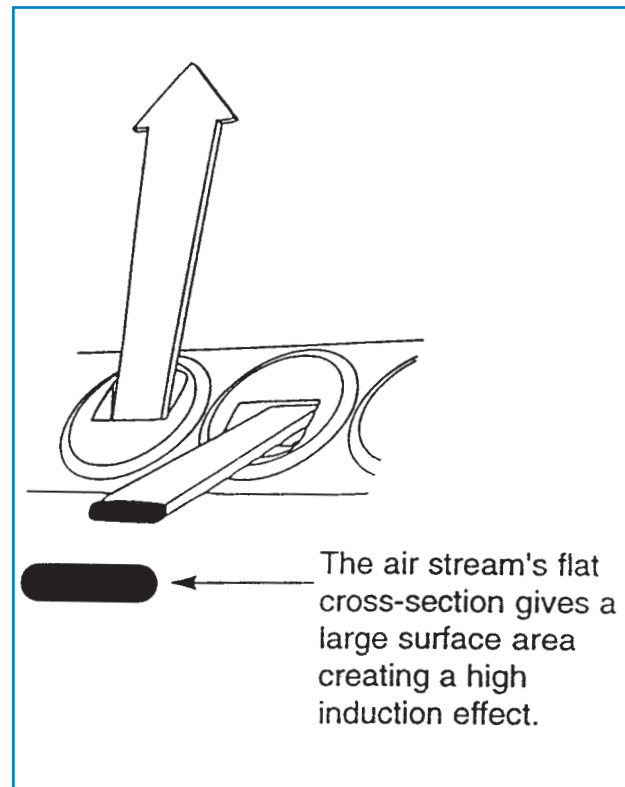

## Calculating of cooling effect - air displacement - temperature difference

The cooling effect for a given displacement of air is calculated by:  $P = 1.2 \times Q \times \Delta t$  (W)

The cooling effect per m<sup>2</sup> of floor area is calculated by:  $P_A = \frac{1.2 \times Q \times \Delta t}{A}$  (W/m<sup>2</sup>)

The displacement of air at a given cooling effect is calculated by:  $Q = \frac{P}{1.2 \times \Delta t}$  (l/s)

The temperature difference  $\Delta t$  is calculated by:  $\Delta t = \frac{P}{1.2 \times Q}$  (°C)

P = Cooling effect in watts (W)

Q = Volume of air in litres per second (l/s)

A = Floor area in square metres (m<sup>2</sup>)

$\Delta t$  = Difference in temperature in degrees centigrade (°C)

PA = Cooling effect per square metre in watts (W/m<sup>2</sup>)

W = Watts

## The Noise Level Generated By The Diffuser

The noise level generated by the diffuser is given by the diffuser's capacity chart in NR, with a room allowance of 8dB.

### Location Of Diffusers In The Room

In larger premises and in rooms with air displacement greater than  $12\text{m}^3/\text{h}$  per  $\text{m}^2$  floor area, the air volume should be divided among several smaller diffusers.

These diffusers should be placed as symmetrically as possible in the room ceiling. N-Series ceiling diffusers with a swirl –pattern will provide a good dispersion of the air mass of the whole room without causing uncomfortable draughts in the occupied zone.

In smaller rooms, and rooms where the displacement of air per  $\text{m}^2$  floor area does not exceed  $12\text{m}^3/\text{h}$ , one diffuser will suffice. If the N-Series ceiling diffuser with a swirl pattern is selected, it can be located off-centre in the room. The diffuser's high induction effect means a good dispersion of the air mass in the room, combined with low air velocity in the occupied zone, will be achieved.

When planning for the positioning of the diffusers, make sure not to place the units closer to walls than the distance the minimum throw allows for. We are always ready to lend any assistance with more detailed planning specifications.

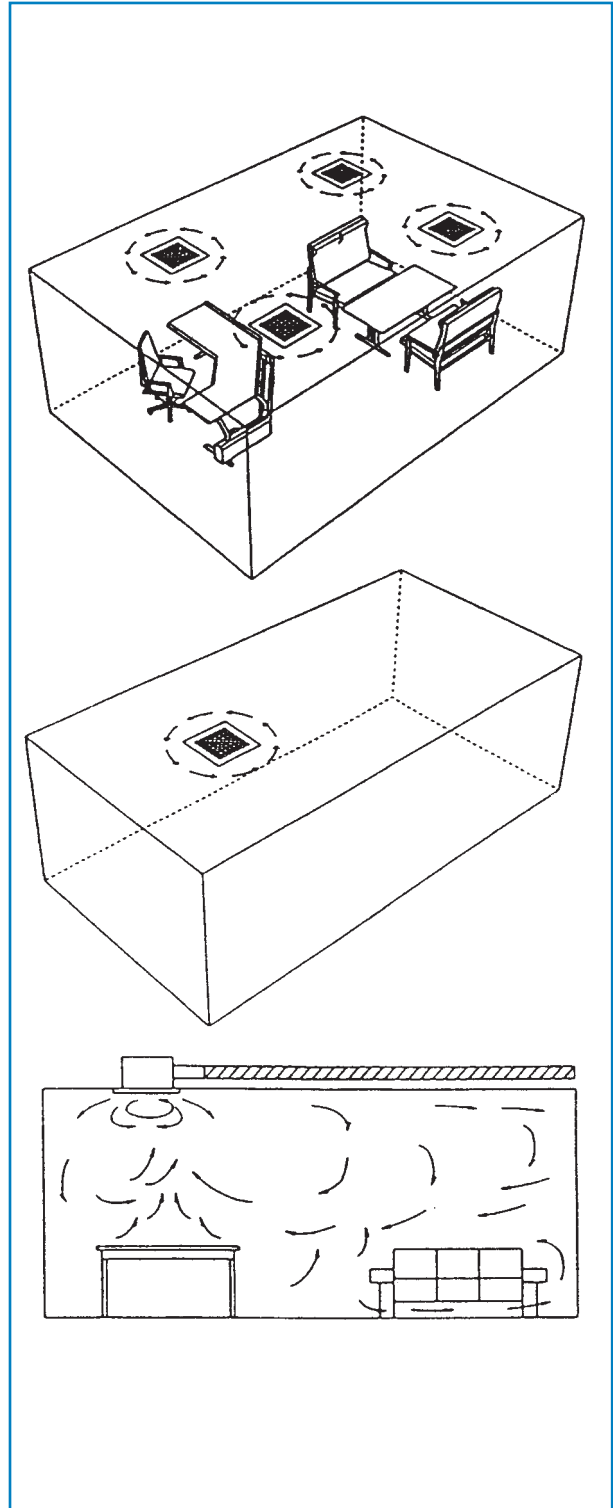

# Flexibility - A major benefit of the N Series Nozzles

## ADJUSTING THE NOZZLE

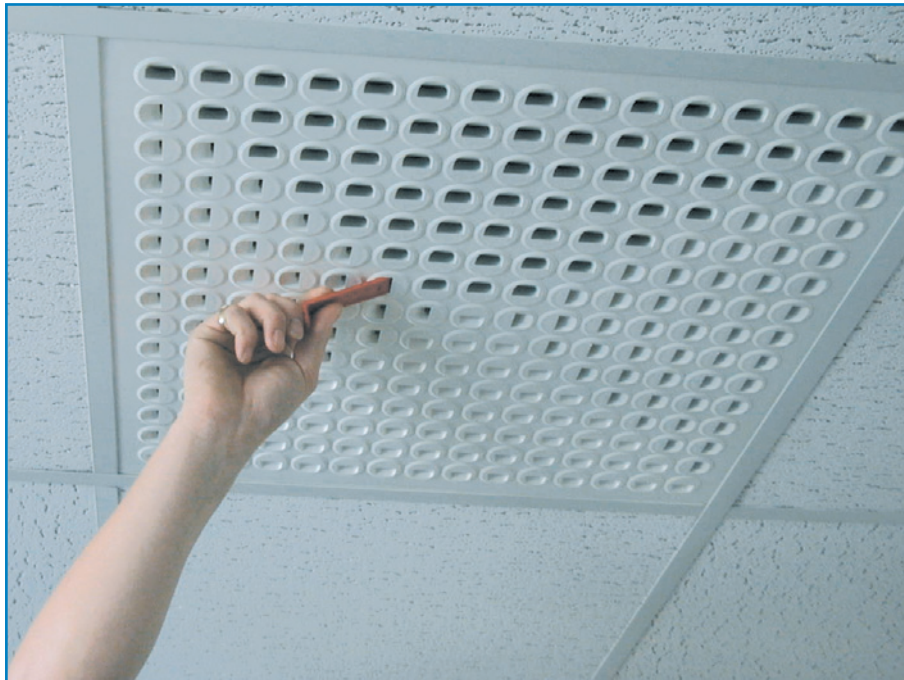

Where the layout of a room is altered requiring a change in the direction of air flow. The nozzles can be easily and rapidly changed to obtain the desired throw.

Changes in the nozzle pattern do not affect air volume, pressure drop or noise level.  
Adjustment is made by a simple, lightweight tool as illustrated



## Ceiling Application

Colman Air Distribution N Series Nozzle Diffusers are available for installation in to all types of ceiling systems with frame styles that cater for surface, recessed, T-bar or threadline mounting.

### ROUND NECK CEILING DIFFUSER

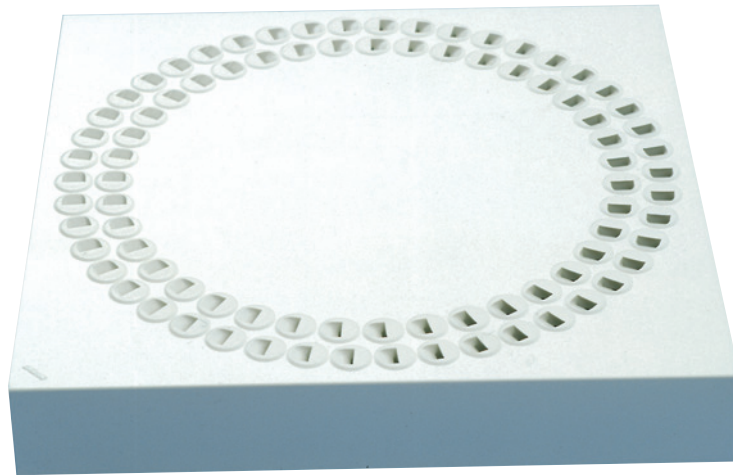

### SQUARE NECK CEILING DIFFUSER





## Plenum Boxes

NN Plenum boxes are specifically designed for use with all square neck styles of N Series diffuser to ensure even distribution of the air over the rear of the diffuser.

When balancing is a requirement, this is achieved through a mono-blade damper (on inlet spigots up to 400dia) fitted into the plenum spigot and operated from the face of the diffuser via a cord.

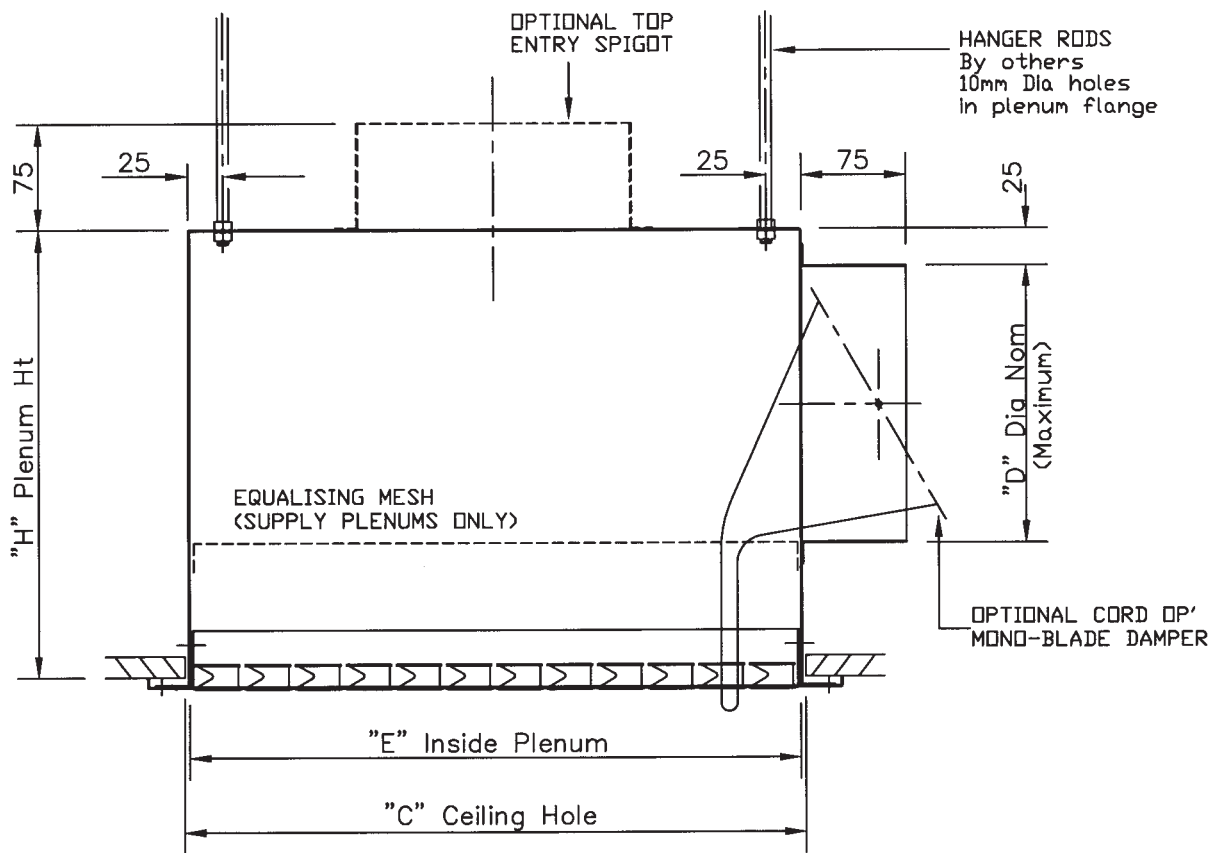

Type NNO

PLENUM SIZE	Inside Plenum E	"D" Dia (MAX)	Height H	H For Top Entry
2500	256x256	250	"D" Dia +125mm	225
3200	328x328	300		"
4300	436x436	400		"
5400	543x543	450		"
6800	687x687	450		"

# DIMENSIONAL DATA

## Fixings:-

The Diffusers will integrate with most types of ceiling systems, catering for Surface, Recessed, T-bar or Threadline Mounting.

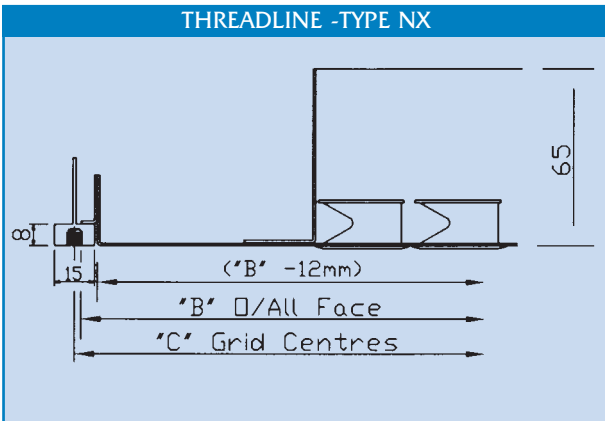
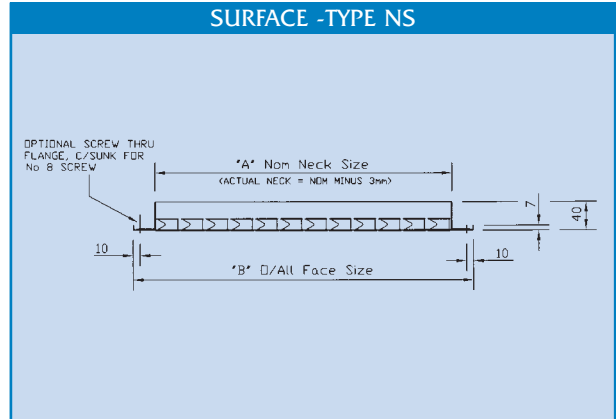
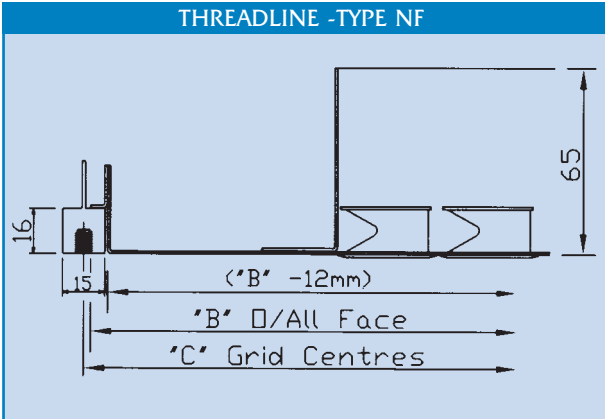

## Type NSS

Diffuser Size	Nom Neck A	O/all Face B	Nozzle Rows	Ceiling Hole C
2530	256 x 256	316 x 316	7 x 7	263 x 263
3240	328 x 328	388 x 388	9 x 9	335 x 335
4350	436 x 436	496 x 496	12 x 12	443 x 443
5460	543 x 543	634 x 634	15 x 15	555 x 555
6880	687 x 687	778 x 778	19 x 19	700 x 700

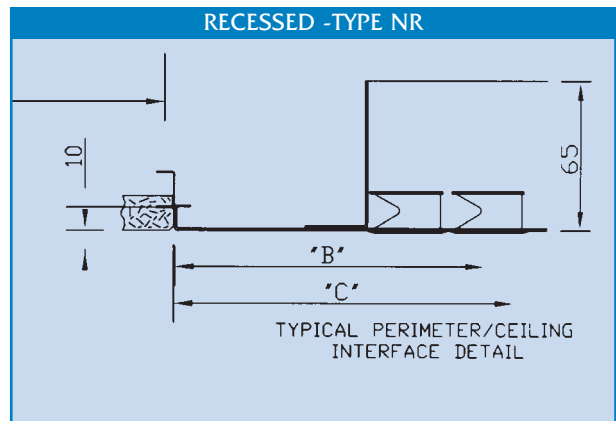
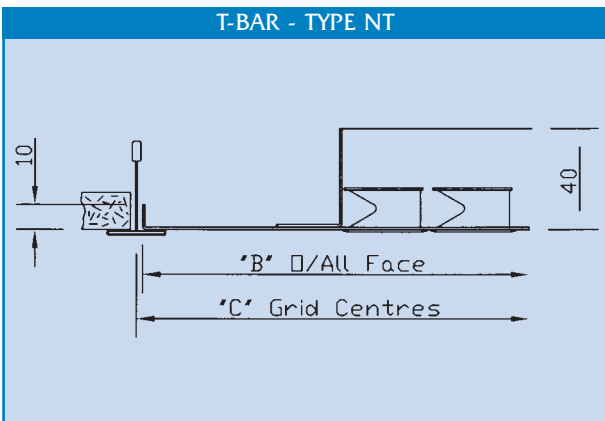

## Type NTS, NFS, NXS

Diffuser Size	Nom Neck A	O/all Face B	Nozzle Rows	Grid Ctrs C
2560	256 x 256	595 x 595	7 x 7	600 x 600
3260	328 x 328	595 x 595	9 x 9	600 x 600
4360	436 x 436	595 x 595	12 x 12	600 x 600
5460	543 x 543	595 x 595	15 x 15	600 x 600
2550	256 x 256	495 x 495	7 x 7	500 x 500
3250	328 x 328	495 x 495	9 x 9	500 x 500
4350	436 x 436	495 x 495	12 x 12	500 x 500

## Type NRS

Diffuser Size	Nom Neck A	O/all Face B	Nozzle Rows	Grid Ctrs C
2560	256 x 256	599 x 599	7 x 7	600 x 600
3260	328 x 328	599 x 599	9 x 9	600 x 600
4360	436 x 436	599 x 599	12 x 12	600 x 600
5460	543 x 543	599 x 599	15 x 15	600 x 600
2550	256 x 256	499 x 499	7 x 7	500 x 500
3250	328 x 328	499 x 499	9 x 9	500 x 500
4350	436 x 436	499 x 499	12 x 12	500 x 500

## CODING - CEILING APPLICATION - SQUARE NECK

"N" Series	FRAME	NECK	QTY NOZZLES	AIR PATTERN	FIXING	FINISH
N	S Surface Mounted (Advise of overflange size)	S Square Neck	F 15 x 15	S Swirl (Supply)	O None	F RAL9010 20%
	T Tee Bar Mounted (595 x 595, 495 x 495)		T 12 x 12	A 4 Way (Supply)	C Concealed Strap	
	R Recessed Mounted (Burgess - 599 x 599, 499 x 499 (Ceiling type to be specified))		N 9 x 9	B 3 Way (Supply)	G Screw through flange (NS ONLY)	
	F Threadline 16mm drop (To suit 15mm "T" Bar as standard)		S 7 x 7	C 2 Way Opposite (Supply)	B Burgess Clip Fix (ceiling type to be specified) (NR ONLY)	
	X Threadline 8mm drop (To suit 15mm "T" Bar as standard)		C 19 x 19	Z 2 Way Corner (Supply)		
	E Threadline 16mm drop (To suit 24mm "T" Bar)			D 1 Way (Supply)		
	W Threadline 8mm drop (To suit 24mm "T" Bar)			E EXTRACT Nozzle		

## EXAMPLES OF ORDER CODES

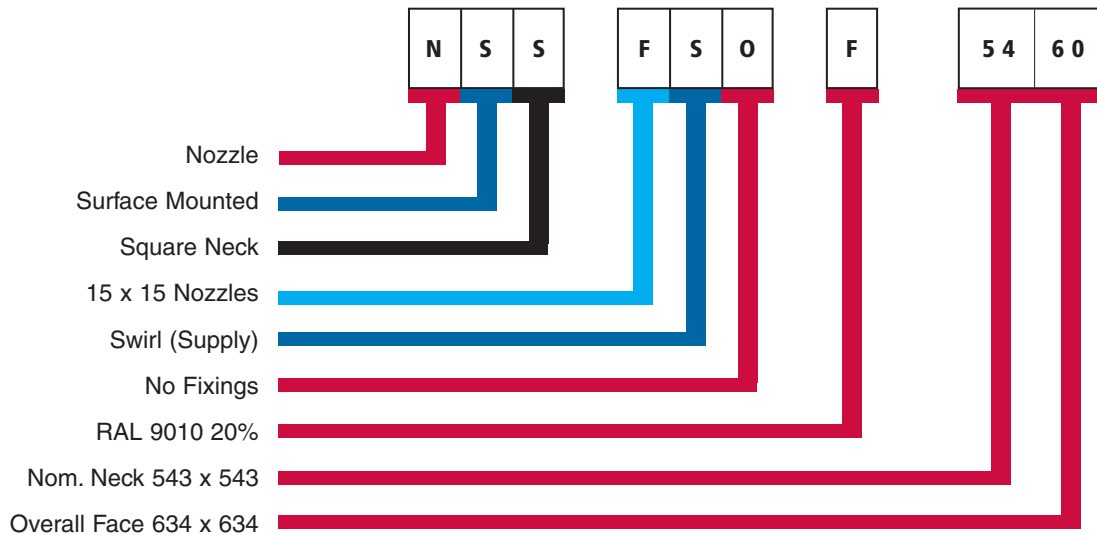

## PLENUM BOXES ORDER CODING

"N" Series	LINING	INSTALLATION	Accessories	ARRANGEMENT	SPIGOT TYPE	SPIGOT SIZE
N	N Unlined	O Raw Edge	O None	S Supply	R Round - Side Entry	A - 100
	L Lined (6mm Bestobel)	C Concealed Strap	M Mono Blade	E Extract	T Round - Top Entry	B - 125
			P Extract Plenum (Painted Matt Black Internally)		W Round - (Flush)	C - 150
			N Extract Plenum c/w mono damper (Painted Matt Black) (Internally)		S Square - Side Entry	D - 200
					Y Square - Top Entry	E - 250
					X Square - (Flush)	G - 350
						H - 400
						J - 450

# SUPPLY PERFORMANCE DATA

## Square Neck Diffuser - Surface / Recessed Mounted

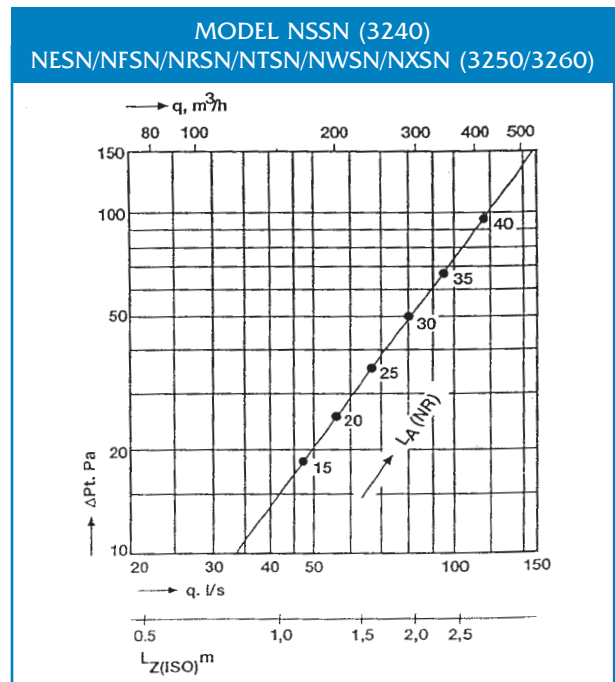
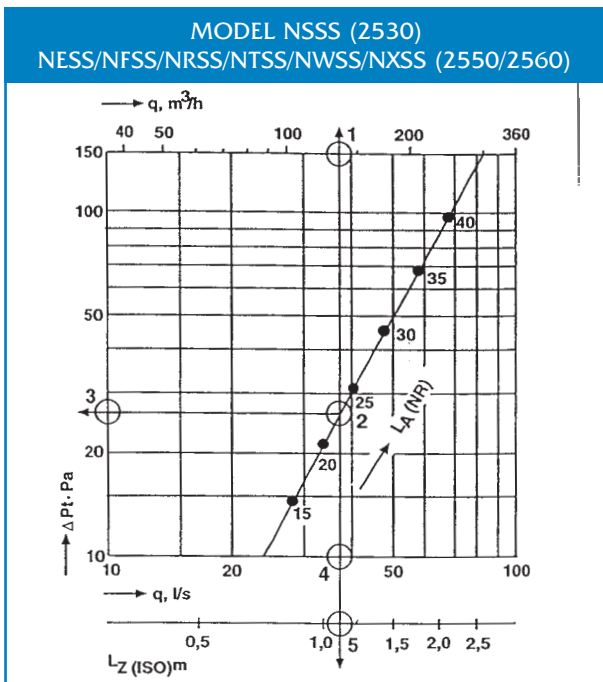

### How To Use The Charts, Example:

1. Air volume 38 l/s
2. Noise level NR22
3. Pressure drop 27Pa
4. Zone length  $L_{Z150} = 1.1$  metres

Note:  $(L_{Z(-10K)} = L_{Z(ISO)} \times 1.1)$

For 10deg 3t increase zone length by 10% for other models increase as indicated.

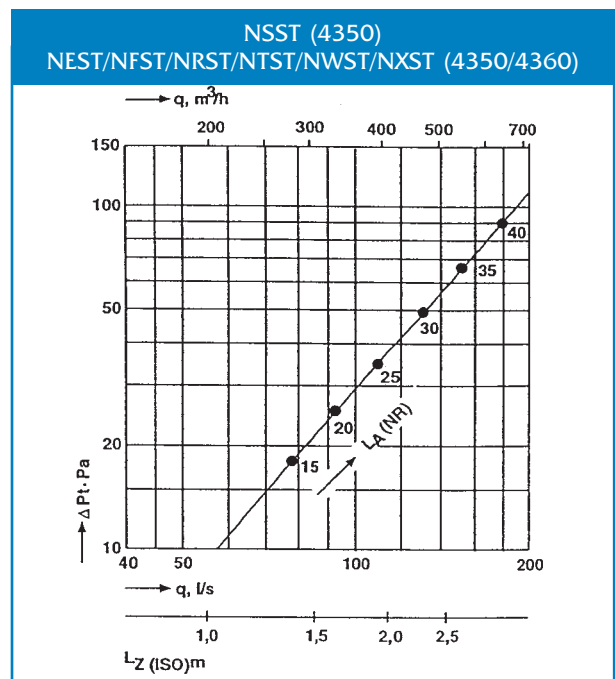

# SUPPLY PERFORMANCE DATA

## Square Neck Diffuser - Tee Bar And Threadline Mounted - Cont.

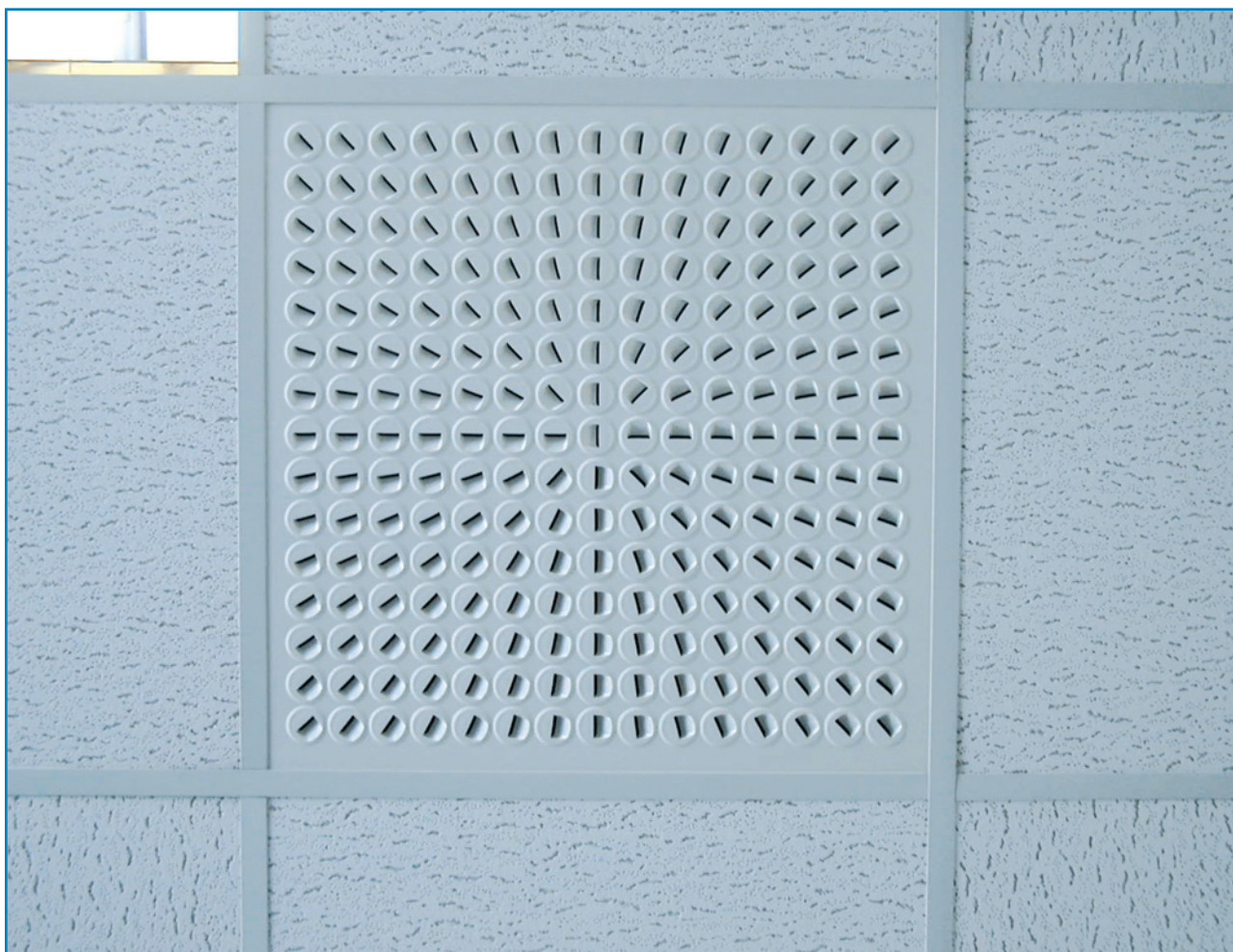
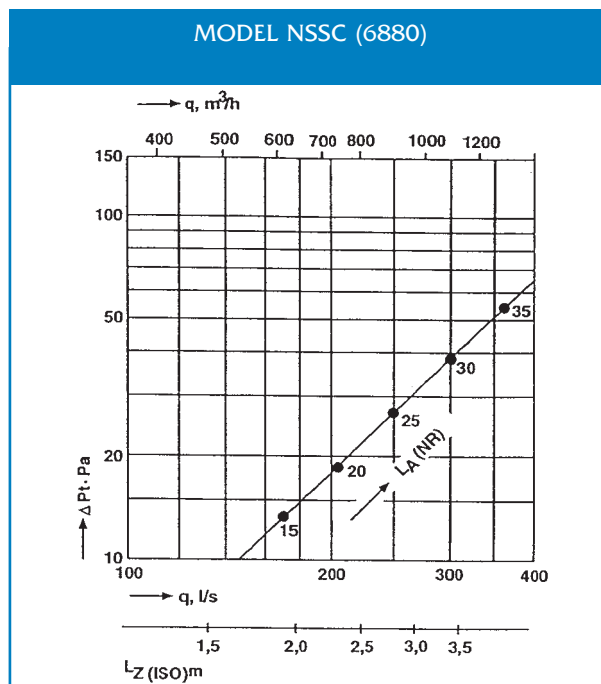
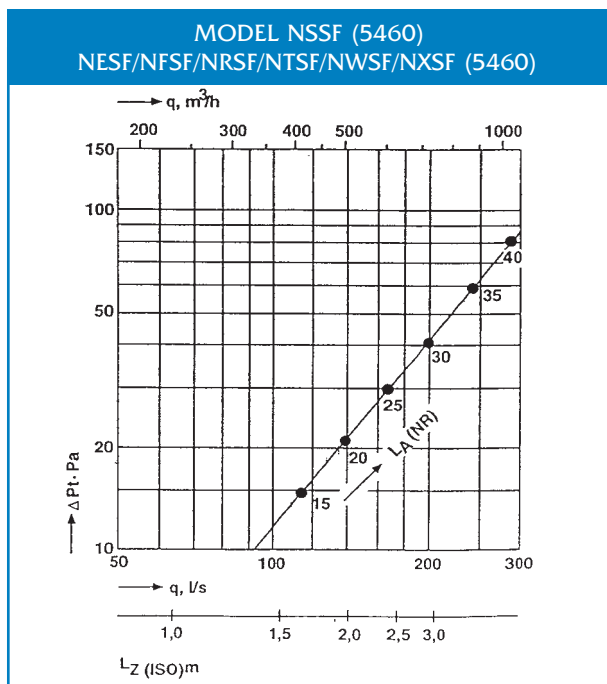

## DIMENSIONAL DATA - ROUND NECK

N-Series Nozzle Diffusers (Ceiling Application)

Model NTR, NFR, NXR, NER & NWR.

c/w 2 No Concentric Rings. (Tee Bar & Threadline)

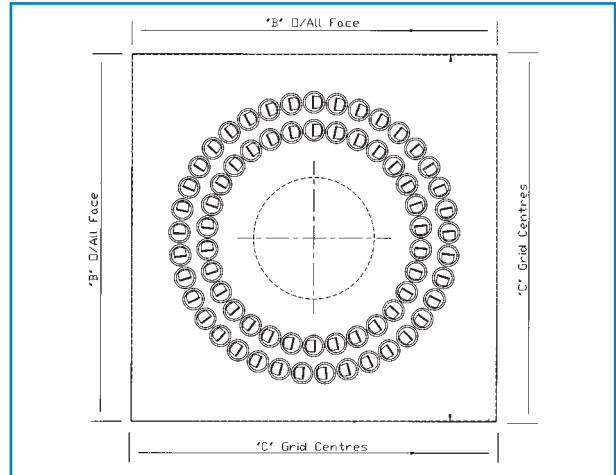

## INTERFACE CROSS SECTION DETAILS

TYPE NTR

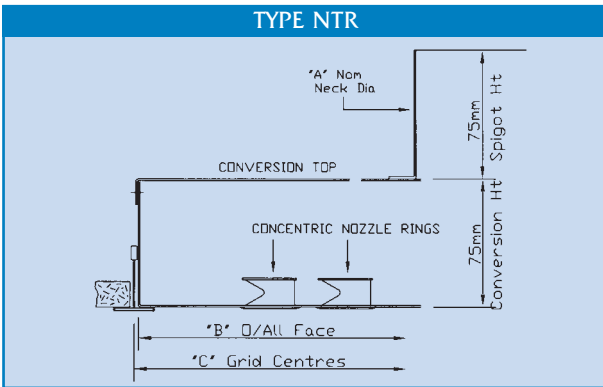

Type NTR, NFR, NXR, NER, NWR

Diffuser Size	Nom Neck A	O/all Face B	Grid Ctrs C
1260	125mm dia	595 x 595	600 x 600
2060	200mm dia	595 x 595	600 x 600

TYPE NFR

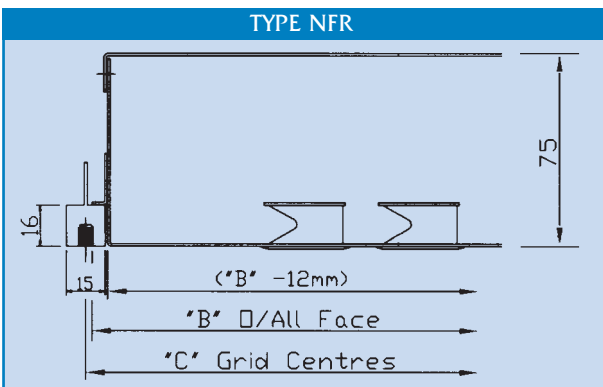

TYPE NXR

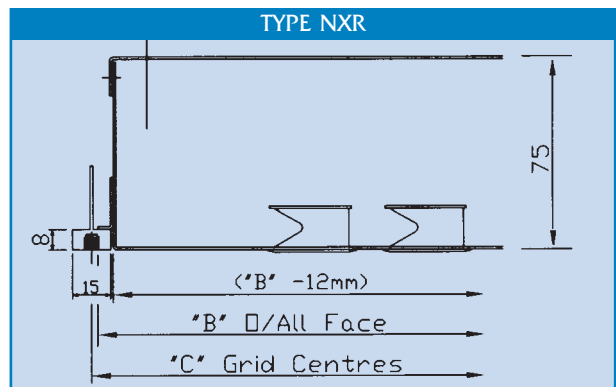

TYPE NER

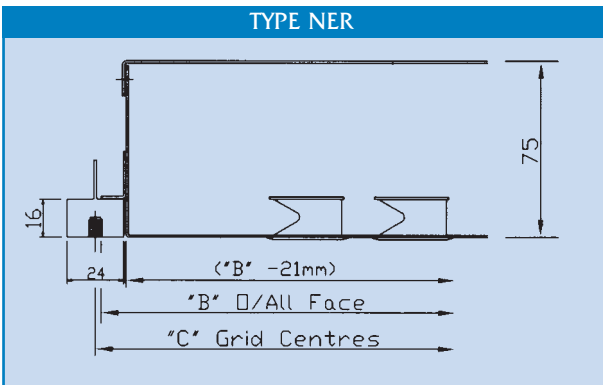

TYPE NWR

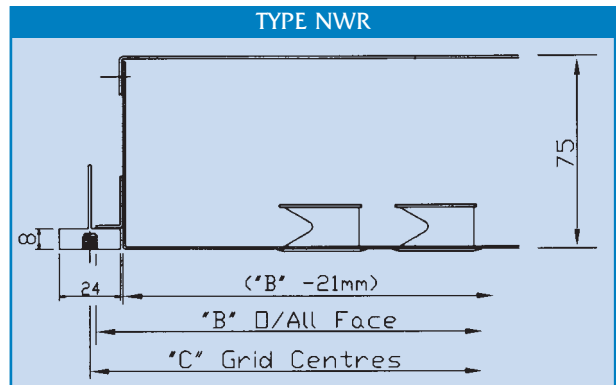

## CODING - CEILING APPLICATION - ROUND NECK

"N" Series	FRAME	NECK	QTY NOZZLES	AIR PATTERN	FIXING	FINISH
N	T Tee Bar Mounted (595 x 595) R Recessed Mounted (Burgess - 599 x 599) (Ceiling type to be specified) F Threadline 16mm drop (To suit 15mm "T" Bar as standard) X Threadline 8mm drop (To suit 15mm "T" Bar as standard) E Threadline 8mm drop (To suit 15mm "T" Bar) W Threadline 8mm drop (To suit 24mm "T" Bar)	R Round Neck	A 2 Rings	S SWIRL (Circular rings within square plate)	S Hanger fitted to conversion	F RAL9010 20%

## EXAMPLES OF ORDER CODES

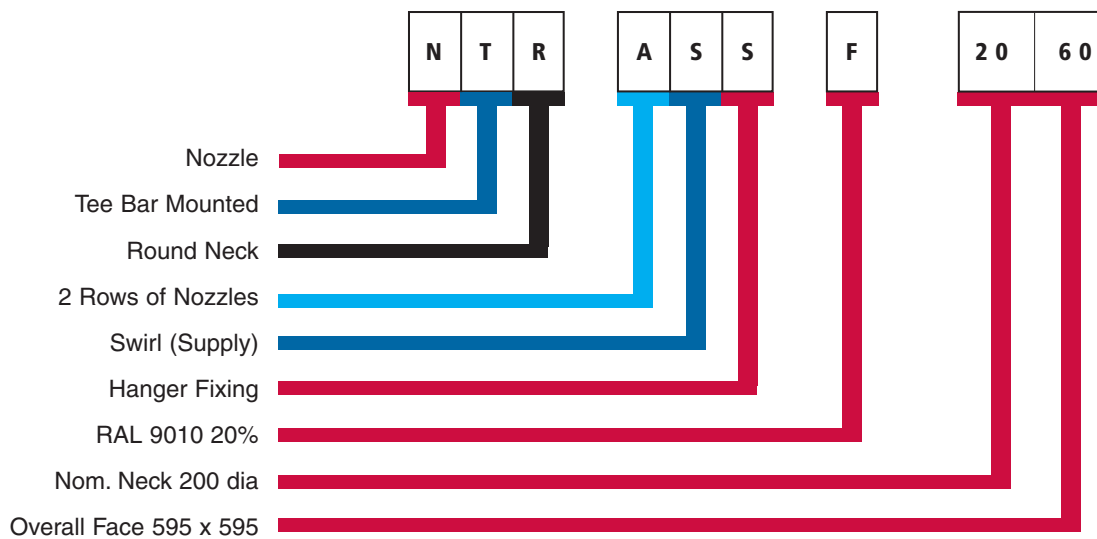

## SUPPLY PERFORMANCE DATA

### Round Neck Diffuser - Tee Bar And Threadline Mounted

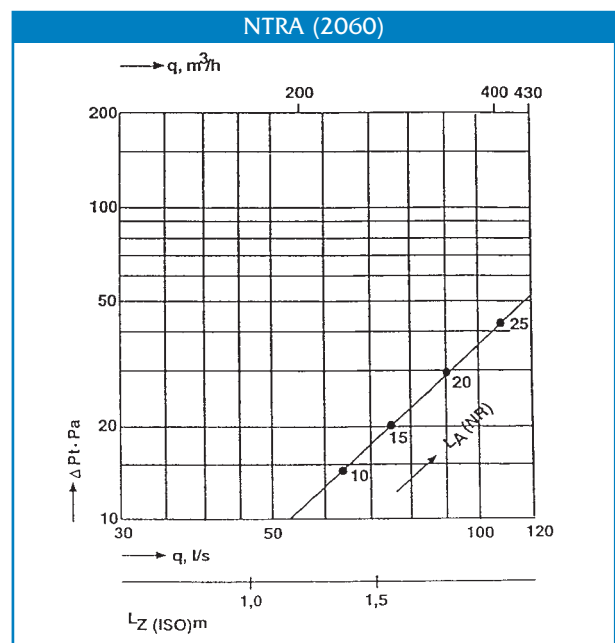
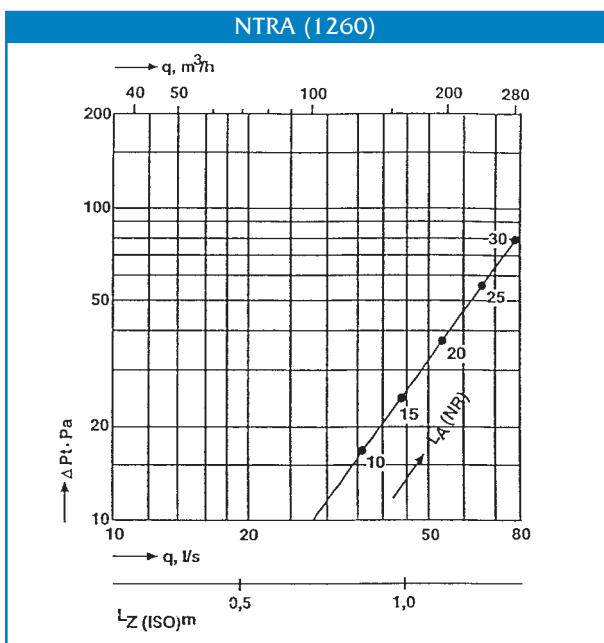

## Sidewall Application

Colman Air Distribution N Series Nozzle Diffusers are ideally suited to be used for sidewall application for installation either with plenum or directly into the ductwork. Whichever method is utilised the end product is aesthetically pleasing and efficient.





# Sidewall Application

"N" Series	FRAME	NECK	QTY NOZZLES	AIR PATTERN	FIXING	FINISH
N	G Sidewall Rectangular	R Round Neck (Includes conversion) S Square Neck	A 7 x 3 B 9 x 3 C 11 x 4 D 12 x 6	D 1 Way C 2 Way	G Screw through face C Concealed strap	F RAL9010 20%

## EXAMPLES OF ORDER CODES

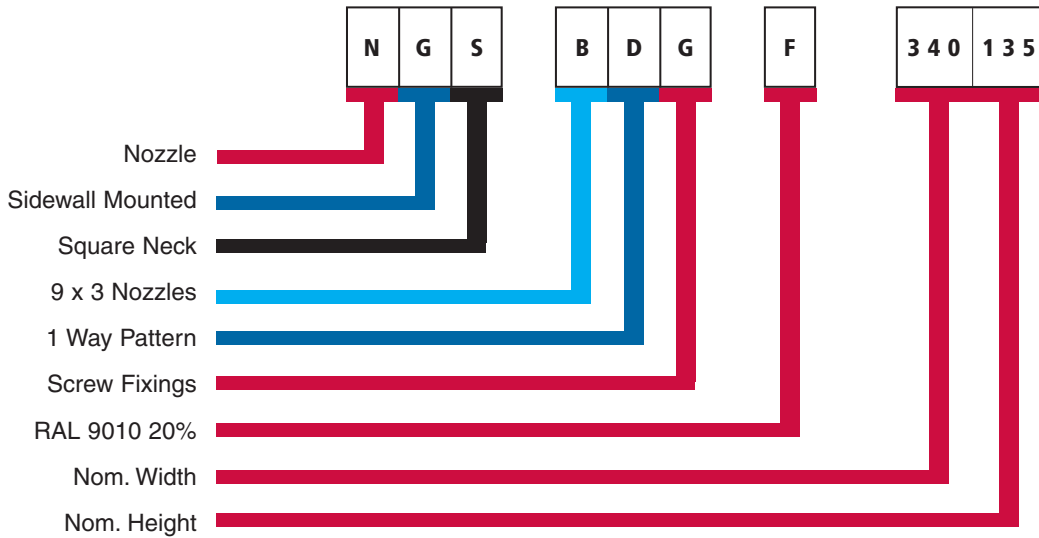

## MODEL NGS SQUARE NECK & NGR ROUND NECK (SUITABLE FOR WALL MOUNTING)

NGS

NGR

DIFFUSER SIZE	Nom Neck A x B	O/all Face C x D	Nozzle Rows	Wall Hole E x F	Spigot Size G Dia Nom
280x135	280x135	340x196	7x3	285x140	100 Dia
340x135	340x135	412x196	9x3	345x140	125 Dia
425x170	425x170	484x232	11x4	430x175	160 Dia
460x245	460x245	520x304	12x6	465x250	200 Dia

# SUPPLY PERFORMANCE DATA

## Sidewall Diffuser

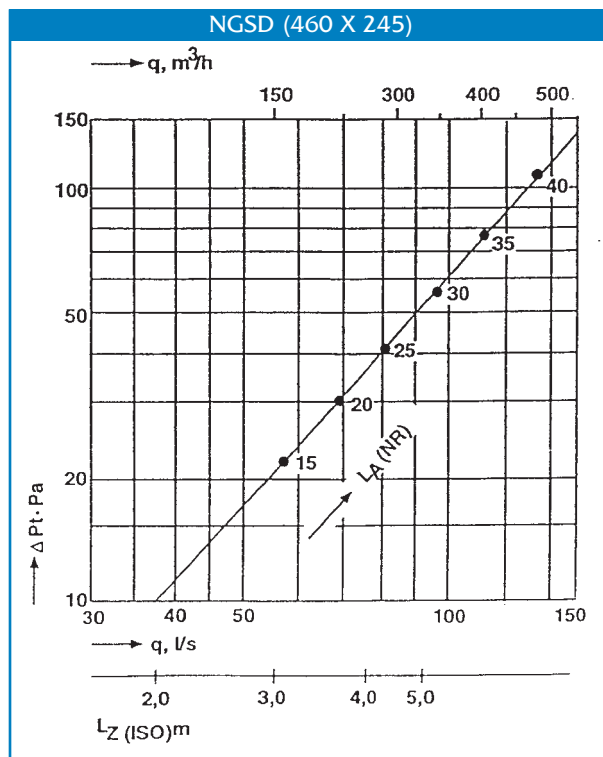
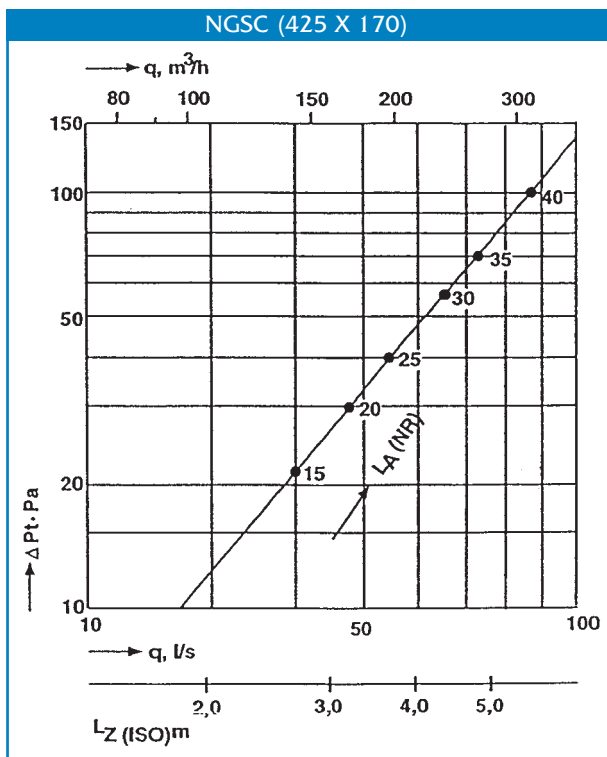
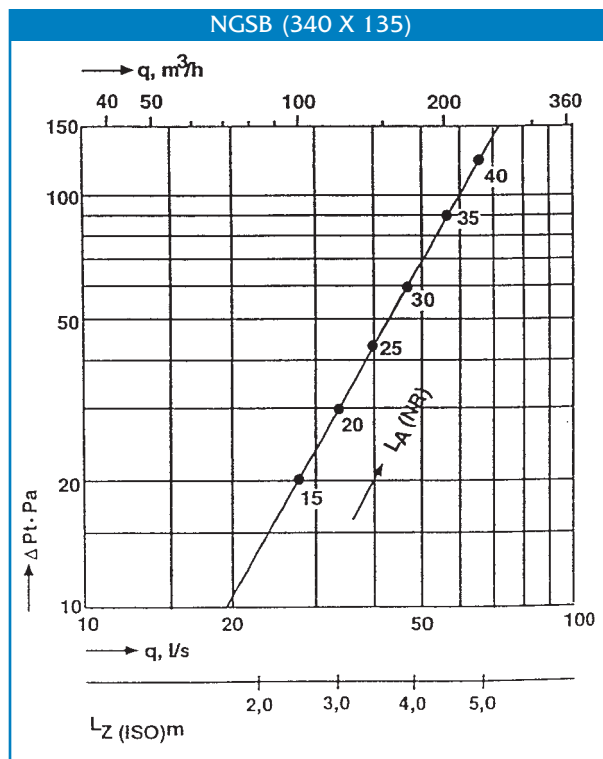
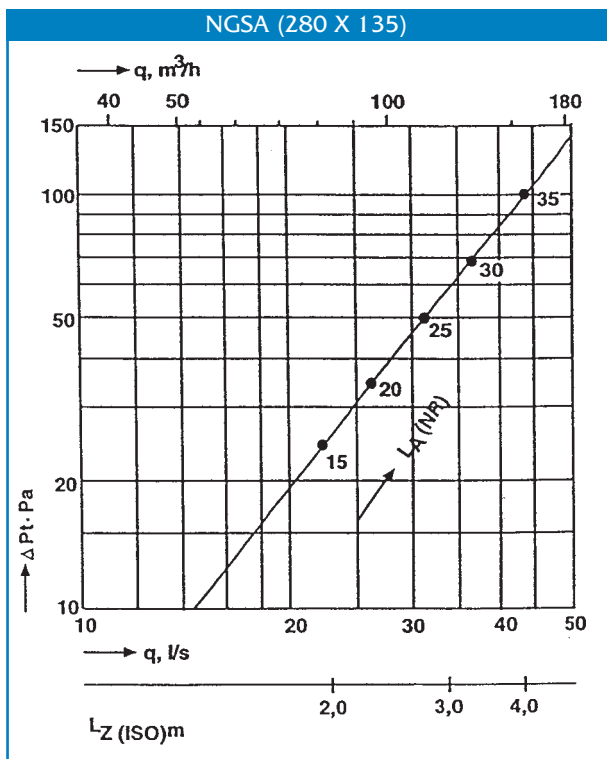

## NOZZLE DIFFUSER - CODING SHEET(DUCT MOUNTED)

"N" Series	FRAME	NECK	QTY NOZZLES	AIR PATTERN	FIXING	FINISH
N	D Duct Mounted	S Square duct R Round Duct	E 24 x 1 (Ducts 200 - 1000mm) F 24 x 2 (Ducts 315 - 1250mm)	D 1 Way C 2 Way	G Screw through face	F RAL9010 20%

## EXAMPLES OF ORDER CODES

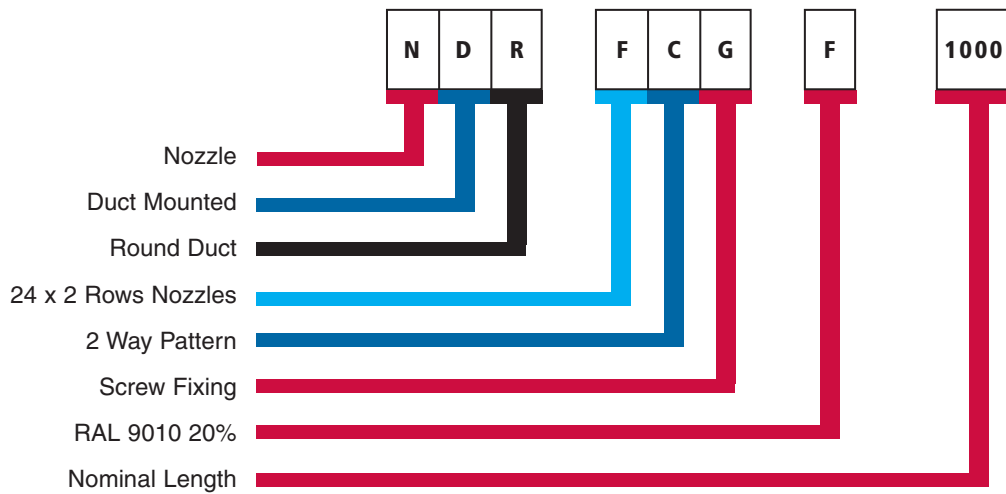

**MODEL NDR**

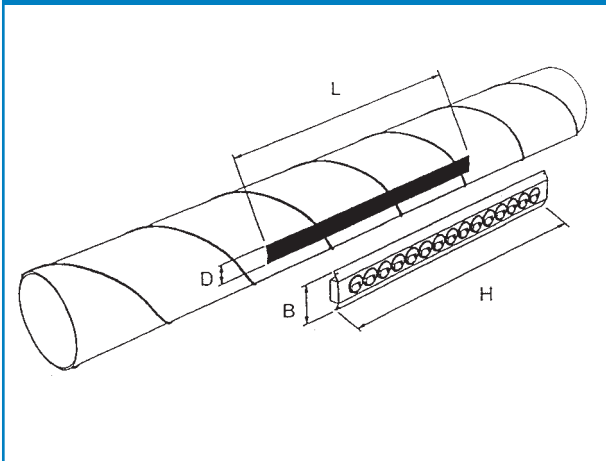

**MODEL NDS**

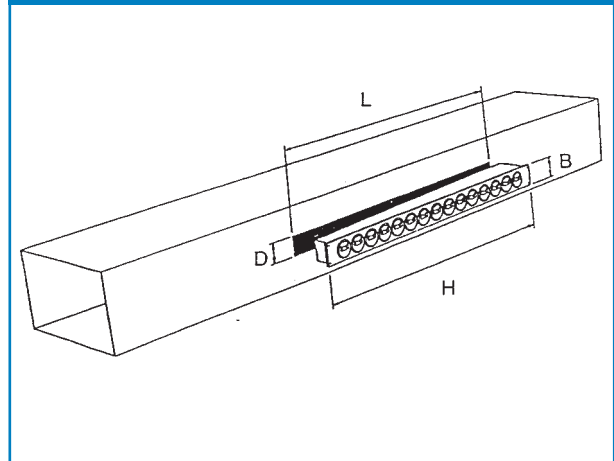

CODE	SIZE	NOM NECK	OVERALL FACE	NOZZLE QTY	DUCT SIZE	DESCRIPTION
NDRE	1000	950 X 60	1000 X 100	25 X 1	dia	DUCT MOUNTED
NDRE	1000	950 X 95	1000 X 133	25 X 2	(200 - 1000)	
NDRE	1000	950 X 60	1000 X 100	25 X 1	(315 - 1250)	
NDRE	1000	975 X 125	1000 X 138	25 X 2		

# SUPPLY PERFORMANCE DATA

## Duct Mounted Diffuser - Rectangular

The chart's applies to air velocities in the ducting of 1-5 m/s

MODEL NDRED & NDSED

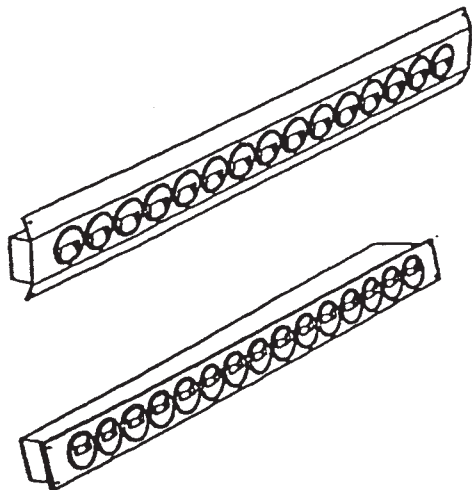

$$L_{Z(-10K)} = L_{Z(ISO)} \times 1.2$$

MODEL NDRED & NDSED

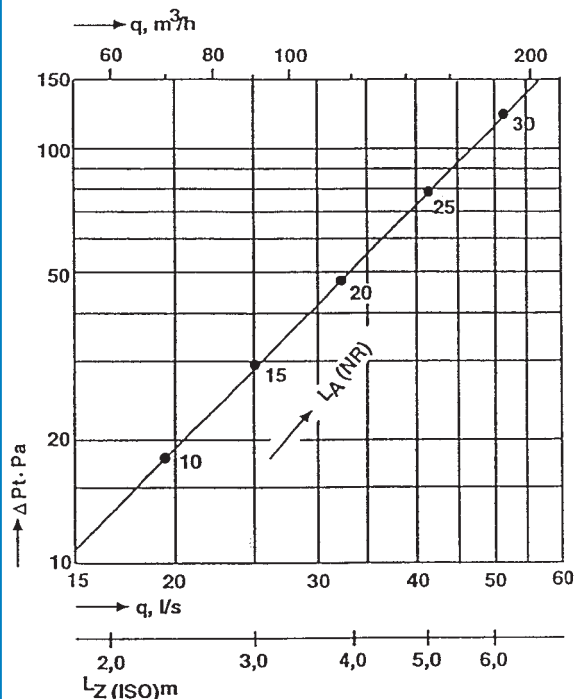

MODEL NDRFD & NDSFD

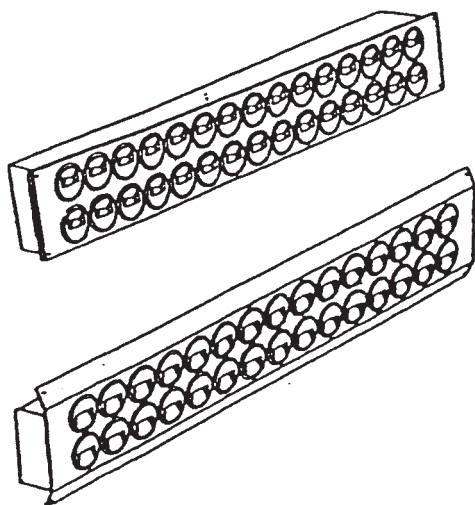

$$L_{Z(-10K)} = L_{Z(ISO)} \times 1.2$$

MODEL NDRFD & NDSFD

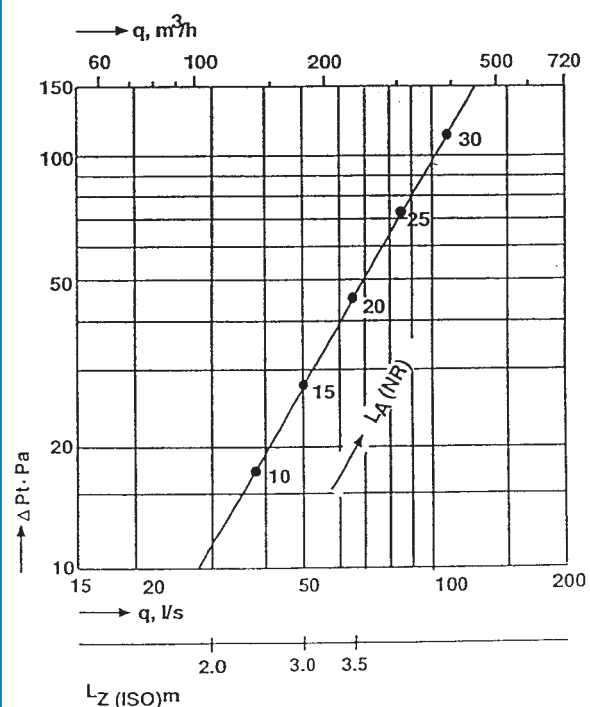

# Linear Application

Colman Air Distribution N Series Nozzle Diffusers are ideally suited to be used for linear applications giving an efficient, alternative approach to meeting air distribution requirements.



## NNB/NNC Plenum Boxes

Colman Air Distribution manufacture a range of high quality, galvanised sheet steel plenum boxes to suit the N range of nozzle. Designed to equalise the air distribution along the diffuser, these plenums are available in standard configurations or purpose made to suit different ceilings, bulkheads and air volumes. For supply air applications they will contain an equalising mesh to equalise the air along the full length of the diffuser. Plenums are normally supplied unlined but can be offered with a variety of acoustic and thermal lining materials. As standard, plenums are supplied with a central circular spigot. Diffuser fixing to the plenums is either via clips (NNB) where the diffuser is fixed first and the plenum is then clipped to the back (as illustrated above) or via universal mounting brackets (NNC) where the plenum is the first fix item.

### NBCL WITH N TYPE PLENUM

Suitable for surface mounting into cut tiles or plaster board ceilings

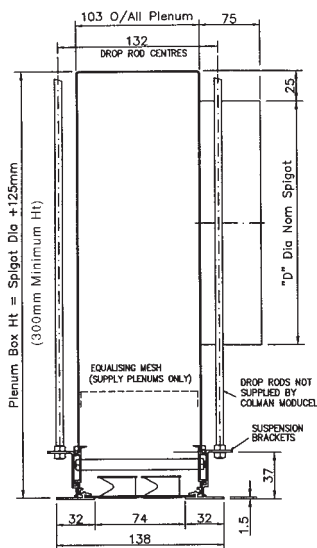

Clip-On Plenum & Bracket Arrangement

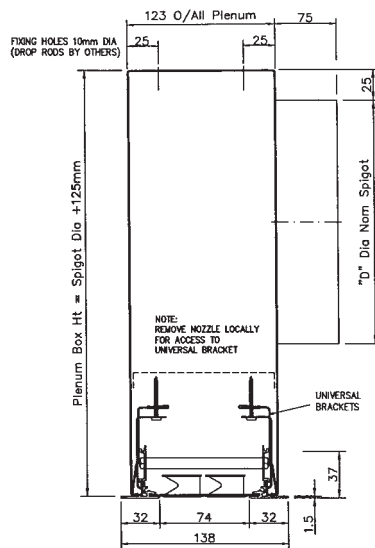

Universal Bracket Arrangement

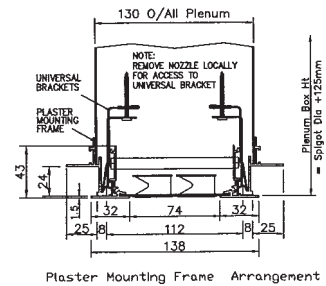

Plaster Mounting Frame Arrangement

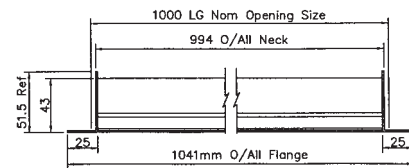

LONGITUDINAL SECTION OF DIFFUSER

Type NBCL

DIFFUSER SIZE	Act'l Neck	O/all Face	Nozzle Rows
1000x2	994x110	1041x138	25x2

## NOZZLE DIFFUSER - CODING SHEET(LINEAR APPLICATION)

"N" Series	FRAME	AIR PATTERN	QTY NOZZLES	ACCESSORIES	FIXING	FINISH
N	B Linear	D 1 Way C 2 Way	L 25 x 2	B Straight (2end caps)	U Universal Bracket H Hanger Bracket P Plaster Frame	F RAL9010 20%

## EXAMPLES OF ORDER CODES

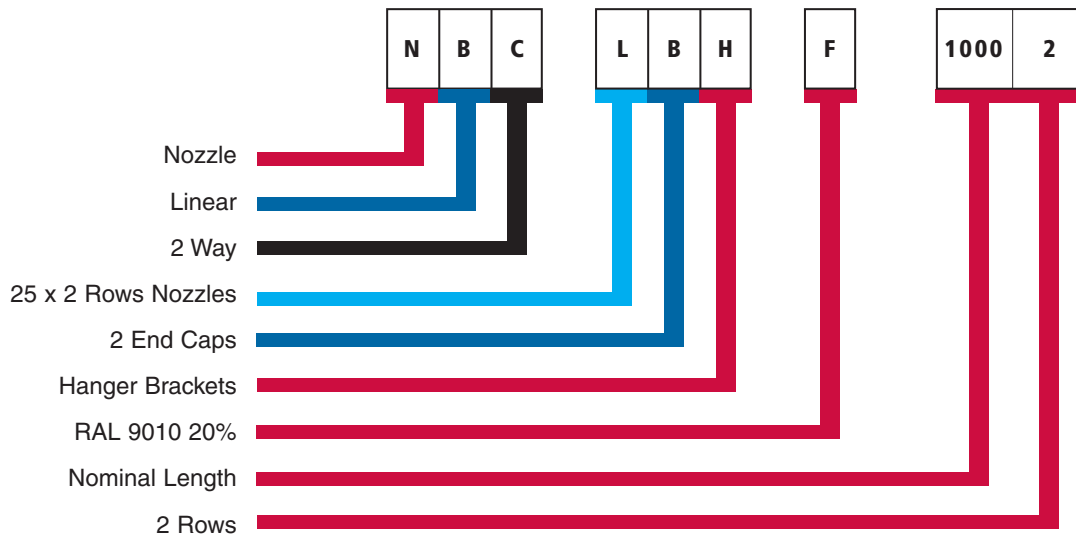

## NOZZLE PLENUM - CODING SHEET

"N" Series	LINING	INSTALLATION	Accessories	ARRANGEMENT	SPIGOT TYPE	SPIGOT SIZE
N	N Unlined	O Raw Edge	O None	S Supply	R Round - Side Entry	A - 100
	L Lined (6mm Bestobel)	U Universal Bracket (NB Type ONLY)	M Mono Blade	E Extract	T Round - Top Entry	B - 125
		P Plaster Mounting Frame (NB Type ONLY)	P Extract Plenum (Painted Matt Black internally)		S Square - Side Entry	C - 150
		C Concealed Strap	N Extract Plenum c/w mono damper (Painted Matt Black internally)		Y Square - Top Entry	D - 200
				X Square - (Flush)	E - 250	
					F - 300	
					G - 350	
					H - 400	
					J - 450	

## LINEAR PERFORMANCE DATA

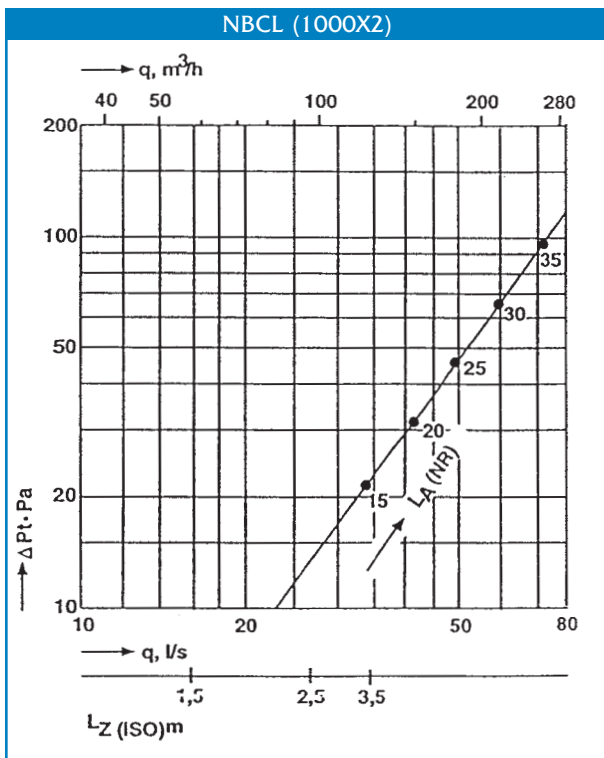

## PROJECTS

**Trafford Centre - Manchester (Retail)**

**Oracle - Reading (Retail)**

**Glan Clwyd Hospital - Clwyd (Medical)**

**Havelock Mills - Manchester (Office)**

**Human Genetics - Oxford (Pharmaceutical)**

**BBC - London (Office)**

**Braehead Park - Glasgow (Retail)**

**Meadowside Leisure Centre - Burton Upon Trent**

# PRODUCT RANGES

GRILLES	DIFFUSERS	LOUVRES
Linear Bar	Linear Slot	External
Ceiling	Louvre Face	Circular
Sidewall	Sidewall	Door
Floor	Perforated Face	Screens
Computer Floor	Circular	Penthouse
Cill	Swirl	Sand Louvres
Single & Double Deflection	Ceiling	Roof Louvres
Egg Crate	Sidewall Fixed & Adjustable	
Hinged Core	Jet Flow / Nozzle	
Door Transfer	Repus Displacement Ventilation	
Security and Prison		
Supply and Extract Valves		

## BESPOKE SERVICE

We offer a bespoke design service where standard products do not fit the requirements of the build, we also supply products in special colours and finishes including bronze, brass, gold and chrome to meet Architectural design specifications.



ENGINEERED AIR  
PRODUCTS

### Colman Air Distribution Limited

Unit 7, High Carr Business Park  
Decade Close, Newcastle-Under-Lyme  
Stoke-on-Trent, Staffordshire ST5 7UH

Telephone: +44 (0)1782 564383  
[www.colmanad.com](http://www.colmanad.com)

We reserve the right to alter specifications without notice and products will sometimes be supplied with modifications which do not strictly comply with the descriptions and illustrations in this publication.