

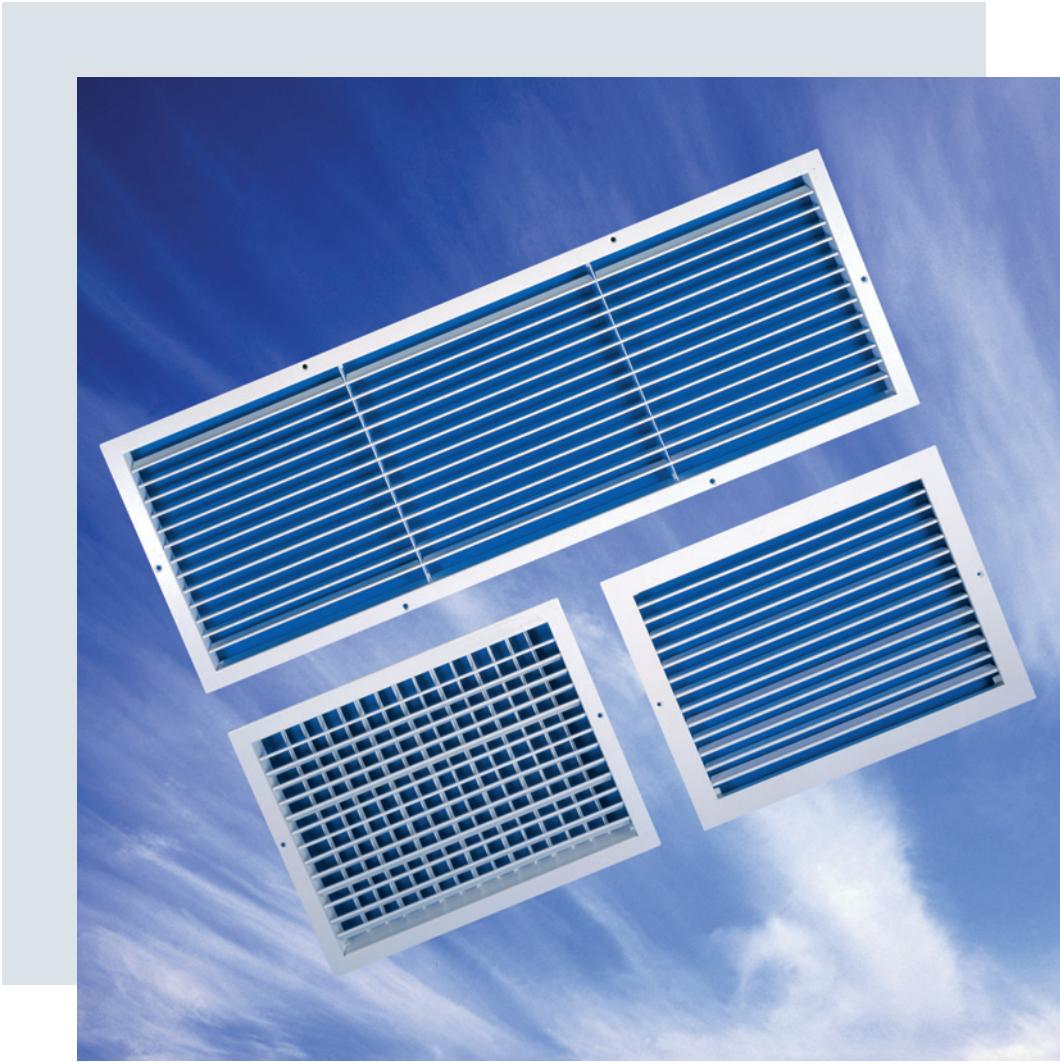

E N G I N E E R E D A I R P R O D U C T S

SUPPLY GRILLES
G SERIES



G

SERIES

SUPPLY GRILLES

G SERIES

QUALITY AND EFFICIENCY WITHOUT COMPROMISE

Application

Colman's range of Supply Grilles have been designed to compliment our extensive range of Return Air Grilles.

The range is suitable for side wall applications and is available in a wide variety of styles and sizes to suit individual application requirements.

Description

With three standard frames and three styles of core, the range provides a flexible group of side wall grilles to meet most functional and installation requirements.

Grilles are manufactured with extruded aluminium flanges, and are complete with aluminium aerofoil blades, resulting in a clean aesthetic appearance.

Grilles utilising our 'B' style frame have integral cores which are retained by spring clips on the rear of the extrusion, whilst the 'H' style houses the core in a U channel panel frame, removable from the face and allowing access to the duct without having to remove the whole grille.

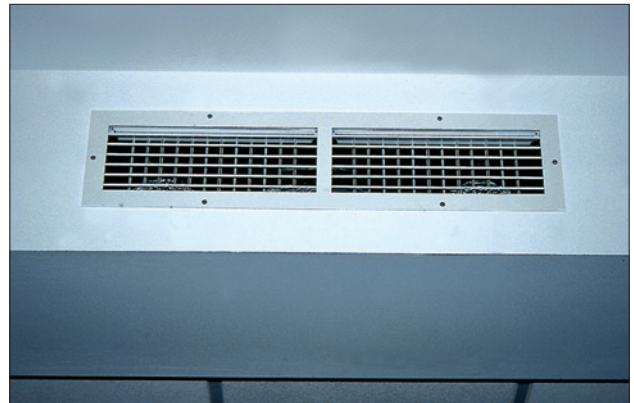
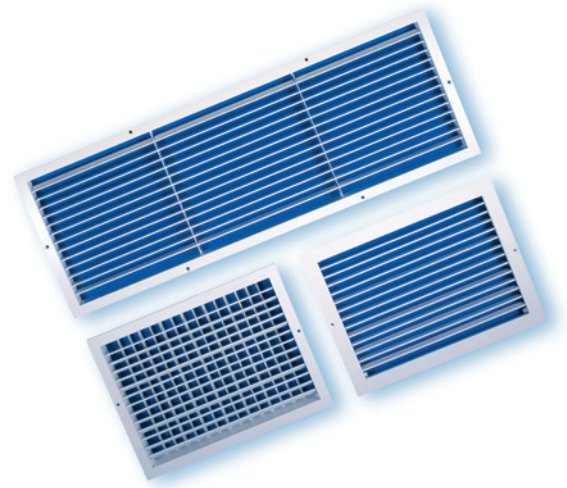

All models are available with opposed blade volume control dampers operable from the face of the grille and can also be supplied with a wide selection of plenum boxes.

Fixings

The most common method for fixing our range of Supply Grilles is screw fixing through the flange face (method G) or through the flange neck (method A). However, to suit the wide selection of products within this range a number of alternative standard fixings arrangements are available, see the product coding section of this brochure for additional information

Finish

Supply Grilles are available as standard in powder coated RAL 9010 Matt White. Grilles which are manufactured totally from aluminium are also available in a natural anodised finish.

Please refer to the product coding section of this brochure for a list of other standard finishes. Special finishes are available upon request.

All grilles are pre-treated utilising a six stage phosphate conversion process conforming to ISO 9171 prior to being powder coated in accordance with BS 6496.

Options and Order Codes

Supply Grilles

1	2 FRAME	3 CORE	4 ACCESSORIES	5 ARRANGEMENT	6 FIXING	7 FINISH
G	0 Core Only B 32mm frame for fixed core H 25mm frame for removable core U U channel	B Aluminium single deflection core D Aluminium double deflection core	0 None V Face operated volume control damper X Face operated volume control damper (painted matt black)	0 None	0 None A Screw fixing thro neck D Universal extended bracket E Spring clips G Screw fixing thro flange H Hanger bracket Ceur 1140 U Universal bracket X Extended hanger bracket	0 Mill finish F RAL 9010 Matt White A Anodised 9 Satin Anodised 8 Matt black C BS00E55 Gloss H BS00E55 Satin D BS00E55 Matt E Ral 9010 Gloss G Ral 9010 Satin 3 Ral 9006 Aluminium 1 Special colours
	Note See product data sheet for frame sizes.	Note See product data sheet for frame sizes.	Note V and X not available on 'U' frame.		Note 1. Code D for grille with VCD's only. 2. D, E, H, U, X, to be used only with B frame.	Note Code A and 9 with frames B, H, and cores B and D only.

Note: The items shown in red print above and below in the code example are the standard option for this product. Unless shown otherwise on any quotation or order the units will be supplied in this configuration.

Example of Order Codes

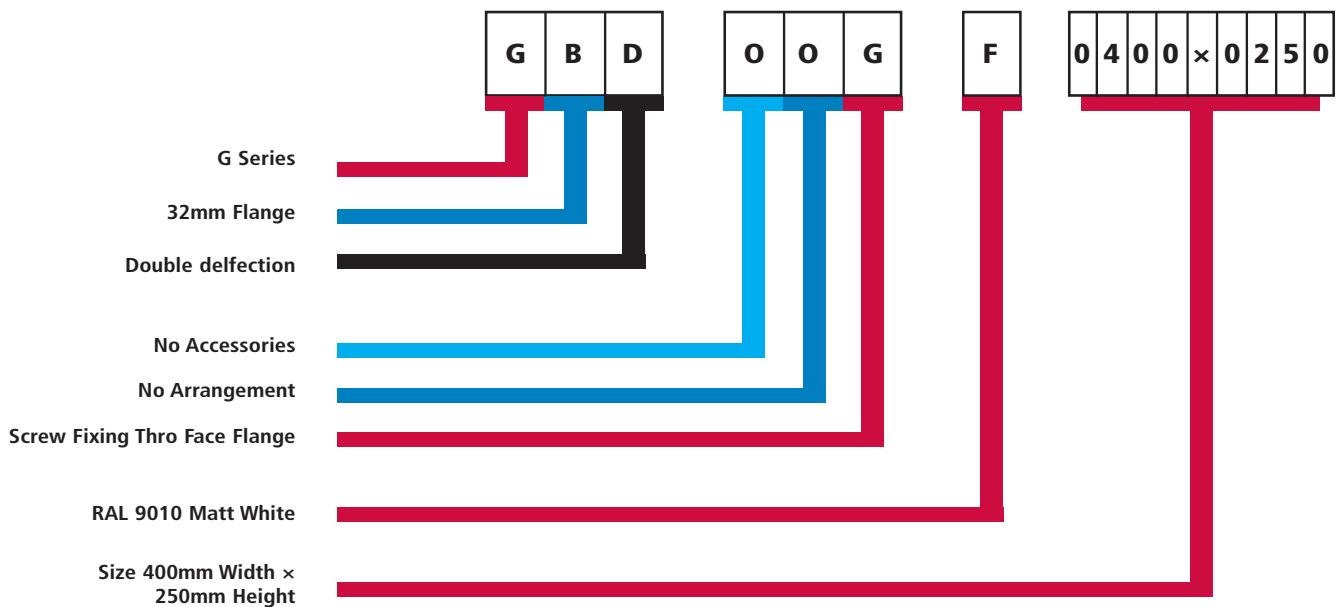

Plenum boxes are available for supply grilles dependant on size and application, please contact the sales office for details.

Performance Data

Models GBB & GBD

- Data is based on a supply air temperature of 11°C below room air temperature and a room ceiling height of 2.7m.
- Throw data are for sidewall applications using straight throw air patterns and with the centre line of the diffuser within 600mm of the ceiling.
- When the centreline of the grille is within 300mm of the ceiling, the grille core should be arranged to provide a 5° upward discharge. When the grille is greater than 300mm away from the ceiling then the core should be arranged to provide a 15° upward deflection.
- Adjustments of the vertical bars provide a wide variation in the horizontal air pattern with a corresponding reduction in throw. To enable selections to be made directly from the nomogram charts for variations in patterns and ceiling height, multiply the required throw by the appropriate factor from the following table. The performance chart can then be used directly to select a grille using this modified throw figure.
- When a grille is installed so that the airstream is not influenced by "ceiling effect", the throw will be reduced by 40%. Multiply the required throw by 1.7 before applying the factor in paragraph 4. Use the grille mounting height in place of the ceiling height to select the appropriate factor.
- Throw is the distance from the face of the grille to the opposite wall. If this distance is equal to the minimum throw of the grille the downwall velocity is approximately 0.4 m/s. If the distance is equal to the maximum throw of the grille the downwall velocity is approximately 0.15 m/s. This downwall velocity is measured at a location 1.5m from the floor and 150mm from the wall surface.
- When two grilles are discharging towards each other, selections should be made so that the grilles will provide a maximum throw equal to half the distance between the two grilles to avoid excessive downdraught in the centre of the space.
- The aspect ratio of a supply grille has a marked effect on the throw performance and the aspect ratio should not be altered without reference to the throw nomogram chart.
- NC data are measured at a location 1.5 metres from floor level and at a 45° angle from the grille face with an 8dB deduction for room effect. Ratings for supply grilles are for a straight pattern. For a 45° widespread pattern an addition of 3dB will apply and for 90° widespread an addition of 7db will apply.
- Dampers fitted to grilles are intended for fine balancing purposes. Excessive dampering to overcome high duct pressures will result in an increased sound level of approximately 8dB per doubling of pressure drop
- Pressure Drop Correction. For 45° widespread the pressure drop should be multiplied by 1.3. for 90° widespread the pressure drop should be multiplied by 2.5.

		Throw Factors					
		Ceiling Height (m)					
Air Pattern		2.7	3.0	3.3	3.6	3.9	4.2
Straight		1.00	1.05	1.10	1.15	1.20	1.25
GBD ONLY	Widespread 45°	1.30	1.37	1.44	1.53	1.62	1.73
	Widespread 90°	1.82	1.91	2.00	2.13	2.26	2.41

- Grilles with straight throw air patterns should be spaced so that a minimum distance of one-third of the required throw exists between adjacent grilles to avoid interference between airstreams. The minimum distance between widespread grilles should be equal to the required throw.

Selection Nomogram

GBB, GBD Sidewall Grilles

Selection Nomogram for GBD Double Deflection Sidewall Grilles & GBB Single Deflection Sidewall Grilles

THROW CORRECTION FOR ASPECT RATIO = WIDTH + HEIGHT = ASPECT RATIO
FACTOR x THROW = ACTUAL THROW

ASPECT RATIO	FACTOR	ASPECT RATIO	FACTOR	ASPECT RATIO	FACTOR
1	1.75	4.5	1.04	8	0.84
1.5	1.54	5	1.00	8.5	0.82
2	1.39	5.5	0.96	9	0.80
2.5	1.29	6	0.94	9.5	0.78
3	1.20	6.5	0.91	10	0.76
3.5	1.14	7	0.88	10.5	0.75
4	1.08	7.5	0.86	11	0.75

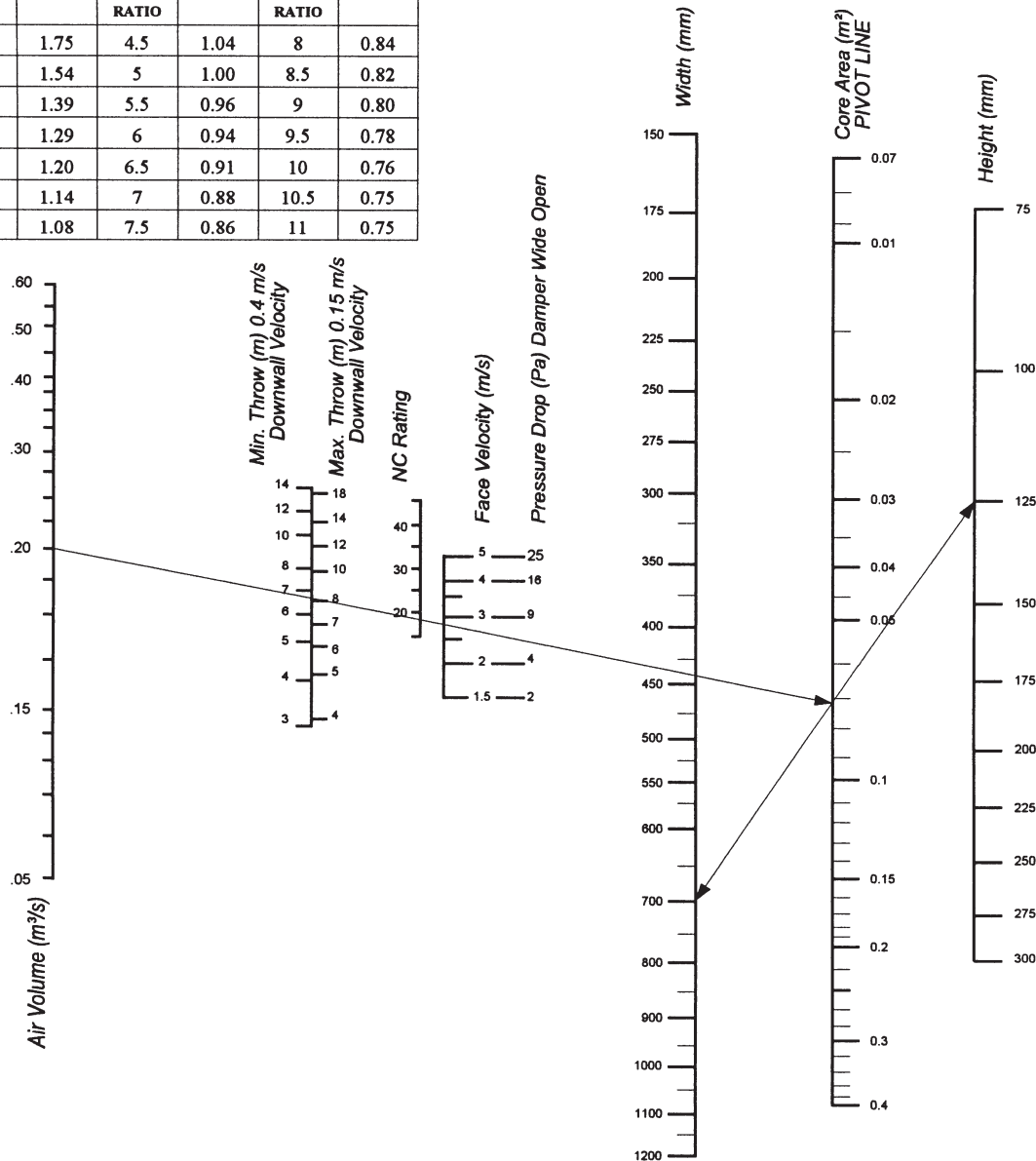

Requirement :-
Air Volume = 0.2 m³/s
Throw = 8.0m
Downwall Velocity = 0.15 m/s

Extracted info. :-
Air Volume = 0.20 m³/s
Throw = 8.0m
NC Sound Rating = <math>NC $= 20$
Pressure Drop = 8Pa
Face Velocity = 2.75 m/s
Size = 700 x 125
Aspect Ratio = $700 \div 125 = 5.6 : 1$

- From Air Volume Scale, draw a straight line through throw line at required value (8.0m)
- Use Pivot Point as shown to obtain width and height of Grille.
- Carry line through to Core Area (Pivot) line. This line passes through NC Sound Rating, Pressure Drop and Face Velocity lines.

Aspect Ratio Correction Factor (from table at top) = 0.96
Actual Throw = $8.0 \times 0.96 = 7.7\text{m}$

The above information applies to ceiling height of 2.7m. Information is based on a supply Air Temperature of 11 °c below room temperature.

Core Areas (m²)

B & H Frame								
Grille Width (mm)	Height (mm)							
	75	100	150	200	250	300	350	400
150	.007	.011	.016	-	-	-	-	-
200	.009	.014	.023	.032	-	-	-	-
250	.012	.018	.029	.041	.052	-	-	-
300	.015	.022	.036	.049	.063	.077	-	-
350	.017	.026	.042	.058	.075	.091	.108	-
400	.020	.029	.048	.067	.086	.105	.124	.143
450	.023	.033	.055	.076	.098	.119	.140	.161
500	.025	.037	.061	.085	.110	.133	.156	.181
550	.028	.041	.068	.094	.120	.147	.173	.199
600	.031	.045	.074	.103	.132	.161	.189	.218
650	.033	.049	.080	.112	.143	.174	.206	.237
700	.036	.053	.087	.121	.154	.189	.222	.256
750	.038	.057	.093	.129	.166	.202	.239	.275
800	.041	.061	.099	.138	.177	.216	.255	.294
850	.044	.064	.106	.147	.189	.230	.271	.313
900	.046	.068	.112	.156	.200	.244	.288	.332
950	.049	.072	.119	.165	.211	.258	.304	.351
1000	.052	.076	.125	.174	.223	.272	.321	.369
1050	.054	.080	.131	.183	.234	.286	.337	.388
1100	.057	.084	.138	.192	.246	.299	.353	.407
1150	.060	.088	.144	.201	.257	.313	.370	.426
1200	.062	.092	.151	.209	.268	.327	.386	.445

Dimensional Data

Supply Grilles

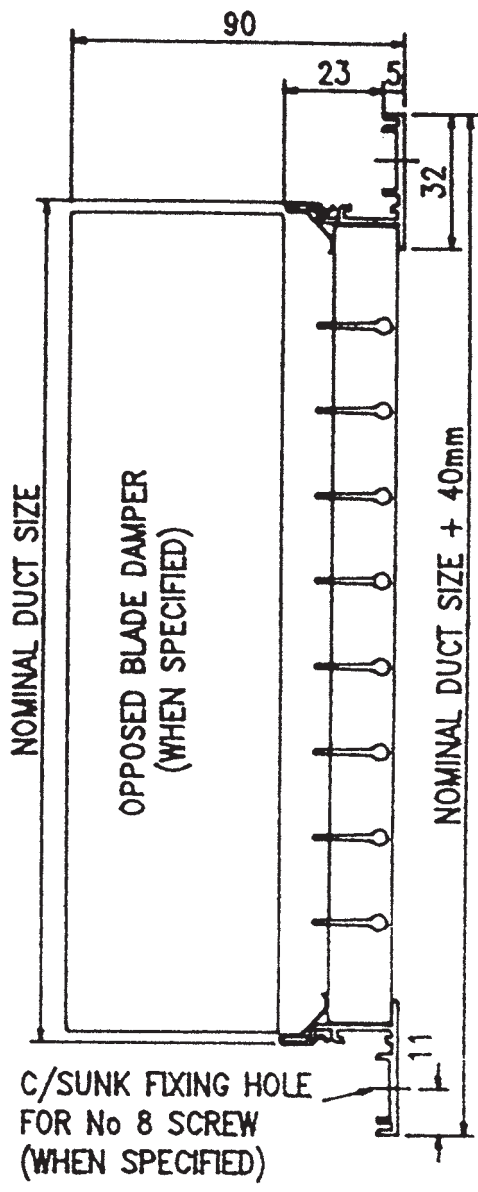

GBB

A single deflection grille with individually adjustable aluminium blades in the horizontal plane held captive within an extruded aluminium outer frame.

MINIMUM SIZE	150 × 75
MAXIMUM SIZE	1200 × 1200
MAXIMUM INDIVIDUAL CORE SIZE	400 × 600

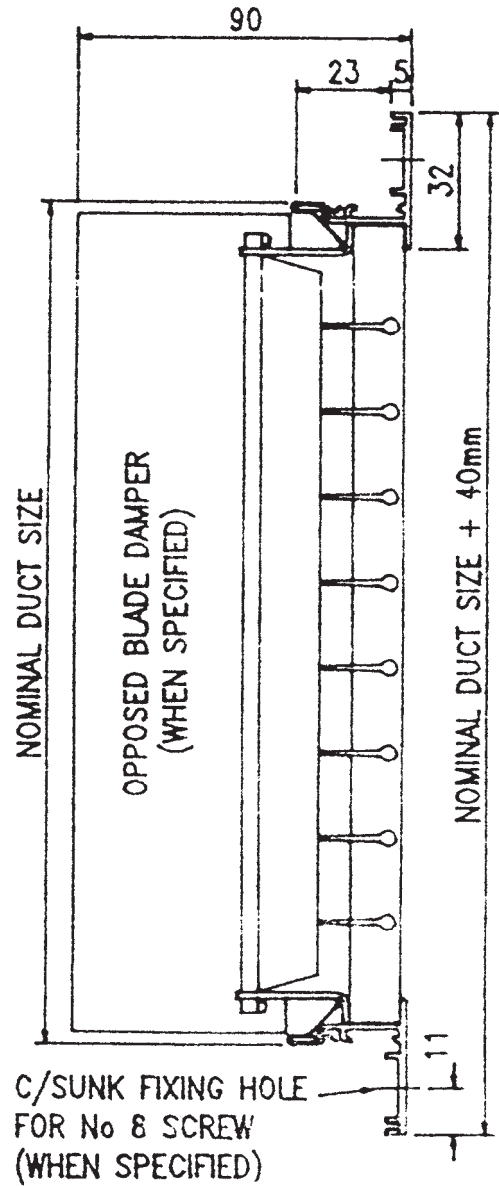

GBD

A double deflection grille with individually adjustable aluminium blades in both horizontal and vertical planes held captive within an extruded aluminium outer frame.

MINIMUM SIZE	150 × 75
MAXIMUM SIZE	1200 × 1200
MAXIMUM INDIVIDUAL CORE SIZE	400 × 600

PRODUCT RANGES

GRILLES	DIFFUSERS	LOUVRES
Linear Bar	Linear Slot	External
Ceiling	Louvre Face	Circular
Sidewall	Sidewall	Door
Floor	Perforated Face	Screens
Computer Floor	Circular	Penthouse
Cill	Swirl	Sand Louvres
Single & Double Deflection	Ceiling	Roof Louvres
Egg Crate	Sidewall Fixed & Adjustable	
Hinged Core	Jet Flow / Nozzle	
Door Transfer	Repus Displacement Ventilation	
Security and Prison		
Supply and Extract Valves		

BESPOKE SERVICE

We offer a bespoke design service where standard products do not fit the requirements of the build, we also supply products in special colours and finishes including bronze, brass, gold and chrome to meet Architectural design specifications.



ENGINEERED AIR
PRODUCTS

Colman Air Distribution Limited

Unit 7, High Carr Business Park
Decade Close, Newcastle-Under-Lyme
Stoke-on-Trent, Staffordshire ST5 7UH

Telephone: +44 (0)1782 564383
www.colmanad.com

We reserve the right to alter specifications without notice and products will sometimes be supplied with modifications which do not strictly comply with the descriptions and illustrations in this publication.